

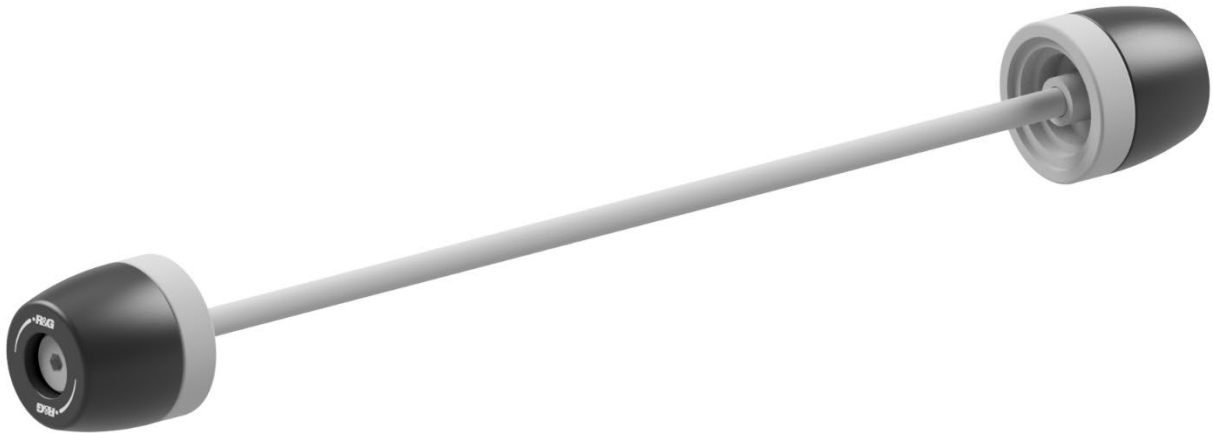

FITTING INSTRUCTIONS FOR SP0105 SWINGARM PROTECTORS



THIS KIT CONTAINS THE ITEMS PICTURED AND LABELLED OVER PAGE.

SOME PARTS MAY BE SHOWN FOR CLARITY OF INSTRUCTIONS ONLY.

DO NOT PROCEED UNTIL YOU ARE SURE ALL PARTS ARE PRESENT.

PLEASE READ ALL INSTRUCTIONS BEFORE PROCEEDING.

IF IN ANY DOUBT WHEN FITTING OUR PRODUCTS, CONSULT ONE OF OUR DEALERS OR HAVE FITTED BY A QUALIFIED TECHNICIAN.

PLEASE NOTE THAT THE WAY THE KIT IS PACKED DOES NOT NECESSARILY REPRESENT THE WAY OF MOUNTING TO THE BIKE.

IN THE EVENT OF RUBBER WASHERS BEING USED TO HOLD COMPONENTS ONTO BOLTS,
THESE RUBBER WASHERS CAN BE THROWN AWAY.

DIGITAL COPIES OF THESE INSTRUCTIONS ARE AVAILABLE FROM:

WWW.RG-RACING.COM

R&G Racing
Unit 1, Shelley's Lane, East Worldham, Alton, Hampshire, GU34 3AQ
Tel: +44 (0)1420 89007 www.rg-racing.com Email: info@rg-racing.com



<u>TOOLS REQUIRED</u>	<u>GENERAL TORQUE SETTINGS</u>
5mm Allen Key x 2 Small amount of super glue	M4 BOLT = 8Nm M5 BOLT = 12Nm M6 BOLT = 15Nm M8 BOLT = 20Nm M10 BOLT = 40Nm M12 BOLT = 40Nm

LEGEND

ITEM NO.	DESCRIPTION	QTY
ITEM 1	SB182 SPINDLE BAR	1
ITEM 2	S1527 - LHS SPACER	1
ITEM 3	S1526 - RHS SPACER	1
ITEM 4	B0575 CRASH PROTECTOR	2
ITEM 5	M8 BARREL NUT	2

ASSEMBLY DIAGRAM

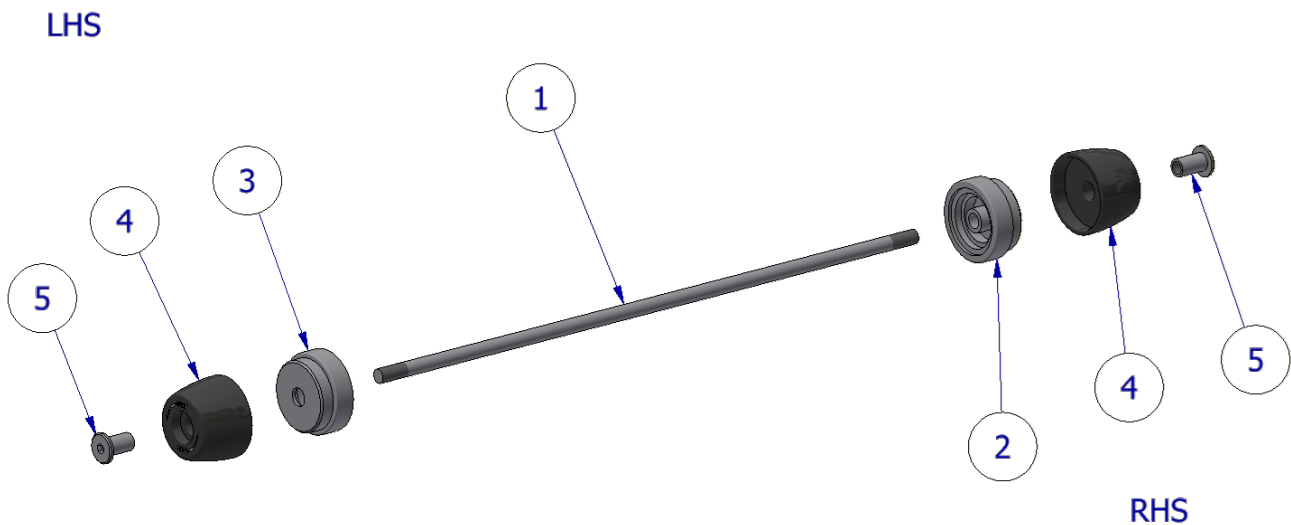



FITTING INSTRUCTIONS

- To start this fitting process, place one barrel nut (**Item 5**) onto the end of the spindle bar (**Item 1**) and tighten until at least half of the spindle bar thread is inside the barrel nut.
- A fitting suggestion: using a small amount of Loctite on the Spindle bar thread will help create an even number of threads on both sides of the swingarm protector once fully tightened.
- Now slide one crash protector bung (**Item 4**) and RHS Spacer (**Item 2**) onto the bar in the configuration shown in the ASSEMBLY DIAGRAM.
- Slide the assembly through the RHS of the rear spindle. Once through place the LHS Spacer (**Item 3**) and remaining crash protector bung (**Item 4**) onto the end of the spindle bar that's protruding through the LHS.
- Finally, place the second barrel nut (**Item 5**) over the exposed end of the spindle bar and tighten with two 5mm Allen keys simultaneously to the correct torque using the **GENERAL TORQUE SETTINGS** table on **PAGE 2**.

ISSUE 1 – 14/05/2024 (MH)

CONSUMER NOTICE

The catalogue description and any exhibition of samples are only broad indications of the Products and R&G may make design changes which do not diminish their performance or visual appeal and supplying them in such state shall conform to the order. The Buyer acknowledges no representation or warranty (other than as to title) has been given or will apply to the Products other than those in R&G's order or confirmation and the Buyer confirms it has chosen the Products as being of merchantable quality and suitable for its particular purposes. Where R&G fits the Products or undertakes other services it shall exercise reasonable skill and care and rectify any fault free of charge unless the workmanship has been disturbed. The Buyer is responsible for ensuring that the warranty on the motorcycle is not affected by the fitting of the Products. On return of any defective Products R&G shall at its option either supply a replacement or refund the purchase money but shall not be liable if the Products have been modified or used or maintained otherwise than in accordance with R&G's or manufacturer's instructions and good engineering practice or if the defect arises from accident or neglect. Other than identified above and subject to R&G not limiting its liability for causing death and personal injury, it shall not be liable for indirect or consequential loss and otherwise its liability shall be limited to the amounts paid by the Buyer for the Products or the fitting or service concerned. These terms do not affect the Buyer's statutory rights.

R&G RACING RETURNS POLICY (NON-FAULTY GOODS)

Returns must be pre-authorized (if not pre-authorized the return will be rejected). Goods may only be returned direct to us if they were purchased direct from us (customer must prove if necessary). Otherwise to be returned to original vendor. Goods must be in re-sellable condition, in the opinion of R&G Racing. All returns are subject to a 25% restocking and handling fee (25% of the gross value exc. P&P – at the prevailing price at time of purchase). The customer must pay any and all carriage charges. No returns of discontinued products, unless within 14 days of purchase. This policy does not affect your statutory rights and does not refer to faulty goods.



NOTICE DE MONTAGE POUR SP0105 PROTECTIONS BRAS OSCILLANT

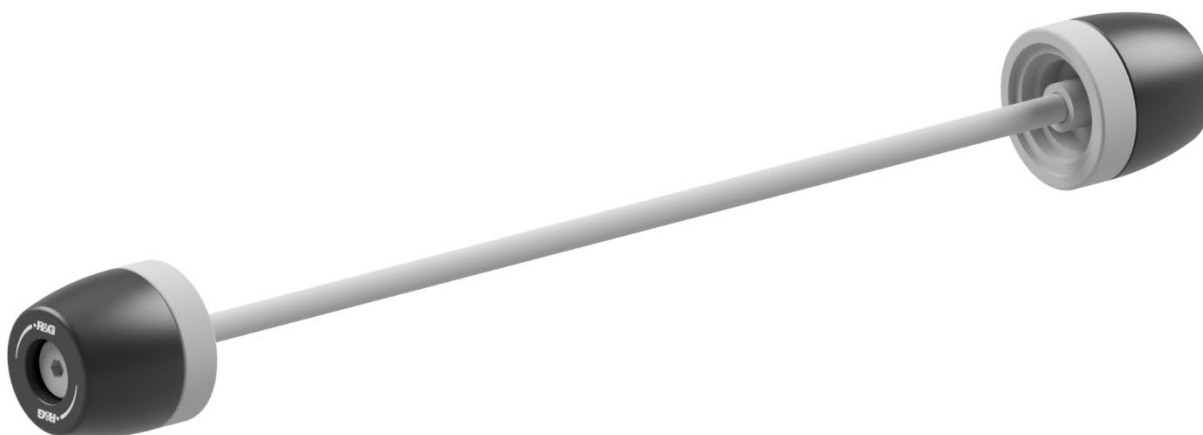

CE KIT CONTIENT LES ARTICLES ILLUSTRÉS ET ÉTIQUETES SUR LA PAGE.

CERTAINES PARTIES PEUVENT ÊTRE PRÉSENTES UNIQUEMENT POUR LA CLARTÉ DES INSTRUCTIONS.

NE PAS PROCÉDER AU MONTAGE TANT QUE VOUS N'ÊTES PAS SÛR QUE TOUTES LES PIÈCES SOIENT PRÉSENTES.

VEUILLEZ LIRE TOUTES LES INSTRUCTIONS AVANT DE CONTINUER.

EN CAS DE DOUTE LORS DU MONTAGE DE NOS PRODUITS, CONSULTEZ UN DE NOS REVENDEURS OU FAITES APPEL À UN TECHNICIEN QUALIFIÉ.

VEUILLEZ NOTER QUE LA FAÇON DONT LE KIT EST EMBALLÉ NE REPRÉSENTE PAS NECESSAIREMENT LA MANIÈRE DE LE MONTER SUR LA MOTO.

SI DES RONDELLES EN CAOUTCHOUC SONT UTILISÉES POUR MAINTENIR LES COMPOSANTS SUR LES BOULONS, ELLES PEUVENT ÊTRE JETÉES.

NOTICE DISPONIBLE AU TÉLÉCHARGEMENT SUR :

WWW.RG-RACING.COM



<u>OUTILS REQUIS</u>	<u>VALEURS DE SERRAGE</u>
Clé Allen 5mm x 2 Un peu de superglue	M4 BOULON = 8Nm M5 BOULON = 12Nm M6 BOULON = 15Nm M8 BOULON = 20Nm M10 BOULON = 40Nm M12 BOULON = 40Nm

LÉGENDE

ARTICLE NO.	DESCRIPTION	QTÉ
ARTICLE 1	SB182 AXE	1
ARTICLE 2	S1527 - ENTRETOISE GAUCHE	1
ARTICLE 3	S1526 - ENTRETOISE DROITE	1
ARTICLE 4	B0575 PROTECTION CRASH	2
ARTICLE 5	M8 ÉCROU À BARILLET	2

SCHÉMA D'ENSEMBLE

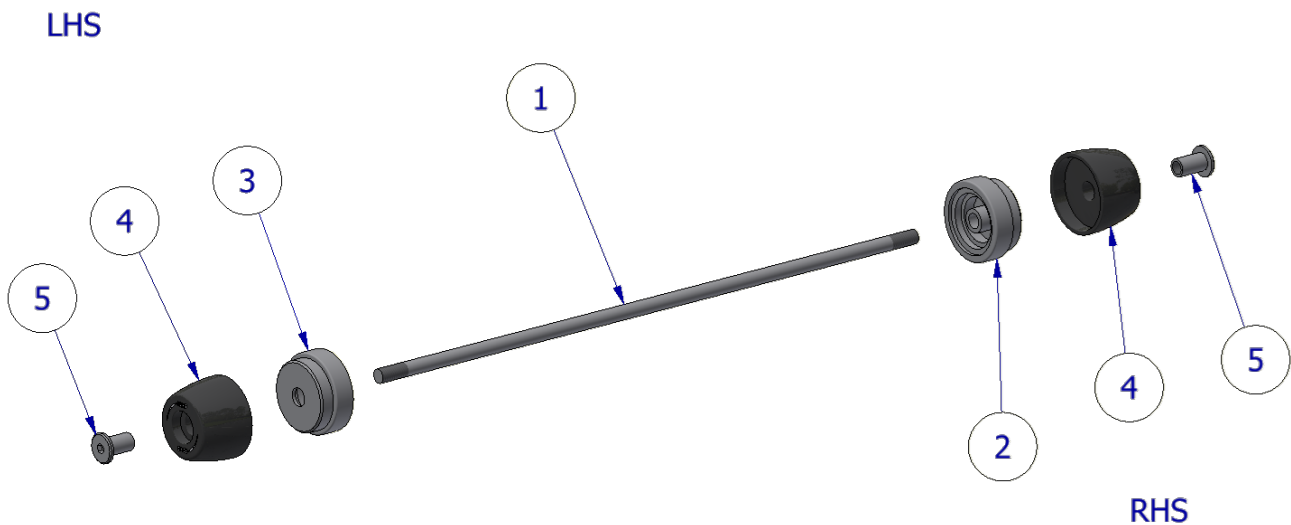



NOTICE DE MONTAGE

- Pour démarrer ce processus de montage, placez un écrou cylindrique (article 5) sur l'extrémité de l'axe (article 1) et serrez jusqu'à ce qu'au moins la moitié du filetage de l'axe soit à l'intérieur de l'écrou cylindrique.
- Suggestion de montage : l'utilisation d'une petite quantité de Loctite sur le filetage de l'axe aidera à créer un nombre pair de filetages des deux côtés de la protection bras oscillant une fois complètement serré.
- Glissez maintenant la protection (article 4) et une entretoise droite (article 2) sur l'axe dans la configuration indiquée sur le SCHÉMA D'ASSEMBLAGE.
- Faites glisser l'ensemble à travers le côté droit de l'axe arrière. Une fois terminé, placez l'entretoise côté gauche (article 3) et la protection restante (article 4) sur l'extrémité de l'axe qui dépasse à travers le côté gauche.
- Enfin, placez le deuxième écrou cylindrique (Article 5) sur l'extrémité exposée de l'axe et serrez simultanément avec deux clés Allen de 5 mm au couple correct en utilisant le tableau RÉGLAGES GÉNÉRAUX DE COUPLE en PAGE 2..

ISSUE 1 - 14/05/2024 (MH)

CONSUMER NOTICE

The catalogue description and any exhibition of samples are only broad indications of the Products and R&G may make design changes which do not diminish their performance or visual appeal and supplying them in such state shall conform to the order. The Buyer acknowledges no representation or warranty (other than as to title) has been given or will apply to the Products other than those in R&G's order or confirmation and the Buyer confirms it has chosen the Products as being of merchantable quality and suitable for its particular purposes. Where R&G fits the Products or undertakes other services it shall exercise reasonable skill and care and rectify any fault free of charge unless the workmanship has been disturbed. The Buyer is responsible for ensuring that the warranty on the motorcycle is not affected by the fitting of the Products. On return of any defective Products R&G shall at its option either supply a replacement or refund the purchase money but shall not be liable if the Products have been modified or used or maintained otherwise than in accordance with R&G's or manufacturer's instructions and good engineering practice or if the defect arises from accident or neglect. Other than identified above and subject to R&G not limiting its liability for causing death and personal injury, it shall not be liable for indirect or consequential loss and otherwise its liability shall be limited to the amounts paid by the Buyer for the Products or the fitting or service concerned. These terms do not affect the Buyer's statutory rights.

R&G RACING RETURNS POLICY (NON-FAULTY GOODS)

Returns must be pre-authorized (if not pre-authorized the return will be rejected). Goods may only be returned direct to us if they were purchased direct from us (customer must prove if necessary). Otherwise to be returned to original vendor. Goods must be in re-sellable condition, in the opinion of R&G Racing. All returns are subject to a 25% restocking and handling fee (25% of the gross value exc. P&P - at the prevailing price at time of purchase). The customer must pay any and all carriage charges. No returns of discontinued products, unless within 14 days of purchase. This policy does not affect your statutory rights and does not refer to faulty goods.

