



FITTING INSTRUCTIONS FITTING INSTRUCTIONS FOR MW0010
MIRROR WIDENERS FOR M10x1.50 RIGHT & LEFT HAND THREADS
35mm lift and 45mm extra width



THIS KIT CONTAINS THE ITEMS PICTURED AND LABELLED OVER PAGE.

SOME PARTS MAY BE SHOWN FOR CLARITY OF INSTRUCTIONS ONLY.

DO NOT PROCEED UNTIL YOU ARE SURE ALL PARTS ARE PRESENT.

PLEASE READ ALL INSTRUCTIONS BEFORE PROCEEDING.

**IF IN ANY DOUBT WHEN FITTING OUR PRODUCTS, CONSULT ONE OF OUR DEALERS
OR HAVE FITTED BY A QUALIFIED TECHNICIAN.**

PLEASE NOTE THAT THE WAY THE KIT IS PACKED DOES NOT NECESSARILY REPRESENT THE WAY OF
MOUNTING TO THE BIKE.

IN THE EVENT OF RUBBER WASHERS BEING USED TO HOLD COMPONENTS ONTO BOLTS,
THESE RUBBER WASHERS CAN BE THROWN AWAY.

DIGITAL COPIES OF THESE INSTRUCTIONS ARE AVAILABLE FROM:

WWW.RG-RACING.COM



<u>TOOLS REQUIRED</u>	<u>GENERAL TORQUE SETTINGS</u>
<ul style="list-style-type: none"> • ALLEN TOOL SET TO INCLUDE 8mm A/F SIZE. • SPECIFIC TOOLS REQUIRED TO REMOVE AND REFIT OEM MIRRORS, IF APPLICABLE. 	M4 BOLT = 8Nm M5 BOLT = 12Nm M6 BOLT = 15Nm M8 BOLT = 20Nm M10 BOLT = 40Nm M12 BOLT = 40Nm

LEGEND

ITEM NO.	DESCRIPTION	QTY
ITEM 1	MIRROR WIDENER (M0639=M10x1.50 RIGHT-HAND THREAD)	1
ITEM 2	M10 x 1.50 x 25.00mm RIGHT-HAND THREAD CAP-HEAD BOLT	1
ITEM 3	NC0010 M10 FLAT CAP	2
ITEM 4	MIRROR WIDENER (M0680=M10x1.50 LEFT-HAND THREAD)	1
ITEM 5	M10 x 1.50 x 25.00mm LEFT-HAND THREAD CAP-HEAD BOLT	1

EXPLODED ASSEMBLY VIEW

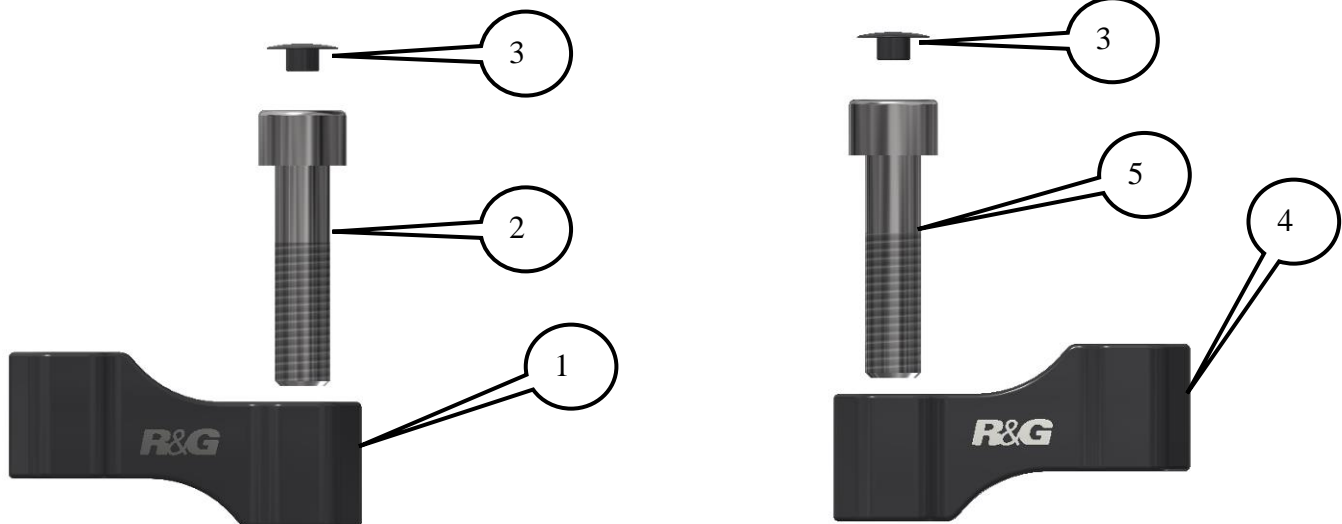

R&G Racing

Unit 1, Shelley's Lane, East Worldham, Alton, Hampshire, GU34 3AQ

Tel: +44 (0)1420 89007 Fax: +44 (0)1420 87301 www.rg-racing.com Email: info@rg-racing.com



FITTING INSTRUCTIONS

- Remove the original mirrors (**PLEASE NOTE ONE MIRROR HAS A LEFT-HAND THREAD**).

RIGHT-HAND THREADED MIRROR WIDENER

- Place the right-hand threaded cap head bolt (**item 2**) into the counter-bore of the right-hand threaded mirror widener (**item 1**) as shown in the **exploded assembly view**.
- Engage the thread into the original mirror mount and position to suit your riding style/position and tighten.
- Refit the original mirror and adjust/tighten for operation.
- Finally, push the flat cap (**item 3**) into the head of the cap-head bolt to give a clean look.

LEFT-HAND THREADED MIRROR WIDENER

- Place the left-hand threaded cap head bolt (**item 5**) into the counter-bore of the left-hand threaded mirror widener (**item 4**) as shown in the **exploded assembly view**.
- Engage the thread into the original mirror mount and position to suit your riding style/position and tighten.
- Refit the original mirror and adjust/tighten for operation.
- Finally, push the flat cap (**item 3**) into the head of the cap-head bolt to give a clean look.

IMPORTANT - WHEN FITTING THIS PRODUCT, IT IS YOUR RESPONSIBILITY TO ENSURE THAT THE PRODUCT IN NO WAY IMPEDES THE OPERATION OF THE MOTORCYCLE AND IS CHECKED REGULARLY FOR TIGHTNESS AND CORRECT OPERATION.

FAILURE TO CHECK THE ABOVE COULD RESULT IN SERIOUS INJURY OR DAMAGE.

ISSUE 1 - 22/09/2021 (NSY)

CONSUMER NOTICE

The catalogue description and any exhibition of samples are only broad indications of the Products and R&G may make design changes which do not diminish their performance or visual appeal and supplying them in such state shall conform to the order. The Buyer acknowledges no representation or warranty (other than as to title) has been given or will apply to the Products other than those in R&G's order or confirmation and the Buyer confirms it has chosen the Products as being of merchantable quality and suitable for its particular purposes. Where R&G fits the Products or undertakes other services it shall exercise reasonable skill and care and rectify any fault free of charge unless the workmanship has been disturbed. The Buyer is responsible for ensuring that the warranty on the motorcycle is not affected by the fitting of the Products. On return of any defective Products R&G shall at its option either supply a replacement or refund the purchase money but shall not be liable if the Products have been modified or used or maintained otherwise than in accordance with R&G's or manufacturer's instructions and good engineering practice or if the defect arises from accident or neglect. Other than identified above and subject to R&G not limiting its liability for causing death and personal injury, it shall not be liable for indirect or consequential loss and otherwise its liability shall be limited to the amounts paid by the Buyer for the Products or the fitting or service concerned. These terms do not affect the Buyer's statutory rights.

R&G RACING RETURNS POLICY (NON-FAULTY GOODS)

Returns must be pre-authorized (if not pre-authorized the return will be rejected). Goods may only be returned direct to us if they were purchased direct from us (customer must prove if necessary). Otherwise to be returned to original vendor. Goods must be in re-sellable condition, in the opinion of R&G Racing. All returns are subject to a 25% restocking and handling fee (25% of the gross value exc. P&P - at the prevailing price at time of purchase). The customer must pay any and all carriage charges. No returns of discontinued products, unless within 14 days of purchase. This policy does not affect your statutory rights and does not refer to faulty goods.

R&G Racing

Unit 1, Shelley's Lane, East Worldham, Alton, Hampshire, GU34 3AQ

Tel: +44 (0)1420 89007 Fax: +44 (0)1420 87301 www.rg-racing.com Email: info@rg-racing.com



NOTICE DE MONTAGE POUR MW0010
ELARGISSEURS DE RETROVISEURS POUR M10x1.50 FILETAGE À GAUCHE ET
À DROITE

Levée de 35 mm et largeur supplémentaire de 45 mm



CE KIT CONTIENT LES ARTICLES ILLUSTRÉS ET ÉTIQUETES SUR LA PAGE.

CERTAINES PARTIES PEUVENT ÊTRE PRÉSENTES UNIQUEMENT POUR LA CLARTE DES INSTRUCTIONS.

NE PAS PROCÉDER AU MONTAGE TANT QUE VOUS N'ÊTES PAS SÛR QUE TOUTES LES PIÈCES SOIENT PRÉSENTES.

VEUILLEZ LIRE TOUTES LES INSTRUCTIONS AVANT DE CONTINUER.

EN CAS DE DOUTE LORS DU MONTAGE DE NOS PRODUITS, CONSULTEZ UN DE NOS REVENDEURS OU FAITES APPEL À UN TECHNICIEN QUALIFIÉ.

VEUILLEZ NOTER QUE LA FAÇON DONT LE KIT EST EMBALLÉ NE REPRÉSENTE PAS NECESSAIREMENT LA MANIÈRE DE LE MONTER SUR LA MOTO.

SI DES RONDELLES EN CAOUTCHOUC SONT UTILISÉES POUR MAINTENIR LES COMPOSANTS SUR LES BOULONS, ELLES PEUVENT ÊTRE JETÉES.

NOTICE DISPONIBLE AU TÉLÉCHARGEMENT SUR :

WWW.RG-RACING.COM

R&G Racing

Unit 1, Shelley's Lane, East Worldham, Alton, Hampshire, GU34 3AQ

Tel: +44 (0)1420 89007 Fax: +44 (0)1420 87301 www.rg-racing.com Email: info@rg-racing.com



<u>OUTILS REQUIS</u>	<u>VALEURS DE SERRAGE</u>
<ul style="list-style-type: none"> CLES ALLEN 8mm. OUTILS SPECIFIQUES REQUIS POUR ENLEVER ET REMONTER LES RETROVISEURS D'ORIGINE, SI POSSIBLE. 	M4 BOULON = 8Nm M5 BOULON = 12Nm M6 BOULON = 15Nm M8 BOULON = 20Nm M10 BOULON = 40Nm M12 BOULON = 40Nm

LÉGENDE

ARTICLE NO.	DESCRIPTION	QTÉ
ARTICLE 1	ÉLARGISSEUR DE RÉTROVISEUR (M0639=M10x1.50 FILETAGE À DROITE)	1
ARTICLE 2	M10 x 1.50 x 25.00mm BOULON CÔTE DROIT	1
ARTICLE 3	NC0010 M10 CAPUCHON PLAT	2
ARTICLE 4	ÉLARGISSEUR DE RÉTROVISEUR (M0680=M10x1.50 FILETAGE À GAUCHE)	1
ARTICLE 5	M10 x 1.50 x 25.00mm BOULON CÔTÉ GAUCHE	1

VUE D'ENSEMBLE

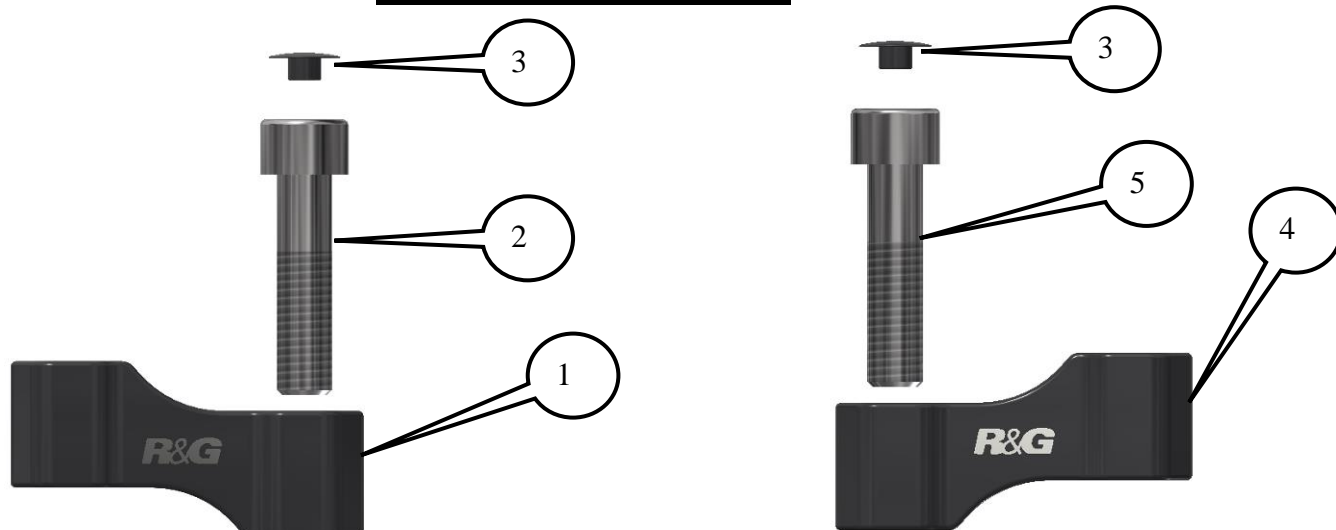



NOTICE DE MONTAGE

- Retirez les rétroviseurs d'origine (**UN DES RÉTROVISEURS PRÉSENTE UN FILETAGE À GAUCHE**).

ÉLARGISSEUR DE RÉTROVISEUR FILETÉ À DROITE

- Placer le boulon à tête cylindrique fileté à droite (article 2) dans le contre-alésage de l'élargisseur de rétroviseur fileté à droite (article 1) puis placer l'une des entretoises (article 1) sur le filetage exposé comme indiqué dans la vue éclatée de l'assemblage.
- Engagez le filetage dans le support de rétroviseur d'origine et positionnez-le en fonction de votre style/position de conduite et serrer.
- Remontez le rétroviseur d'origine et ajustez/serrez pour le fonctionnement.
- Enfin, poussez le capuchon plat (article 3) dans la tête du boulon à tête cylindrique pour donner un aspect net.

ÉLARGISSEUR DE RÉTROVISEUR FILETÉ À GAUCHE

- Placer le boulon à tête cylindrique fileté gauche (article 5) dans le contre-alésage de l'élargisseur de rétroviseur fileté gauche (article 4) comme indiqué dans la vue éclatée de l'assemblage.
- Engagez le filetage dans le support de rétroviseur d'origine et positionnez-le en fonction de votre style/position de conduite et serrer.
- Remontez le rétroviseur d'origine et ajustez/serrez pour le fonctionnement.
- Enfin, poussez le capuchon plat (article 3) dans la tête du boulon à tête cylindrique pour donner un aspect propre..

IMPORTANT - LORS DE L'INSTALLATION DE CE PRODUIT, IL EST DE VOTRE RESPONSABILITÉ DE VOUS ASSURER QUE LE PRODUIT NE PUISSE EN AUCUN CAS ALTÉRER LE FONCTIONNEMENT DE LA MOTO ET QUE SON SERRAGE ET SON BON FONCTIONNEMENT SOIENT VÉRIFIÉS RÉGULIÈREMENT.

NE PAS VÉRIFIER LES ÉLÉMENTS CI-DESSUS POURRAIT ENTRAÎNER DES BLESSURES OU DES DOMMAGES GRAVES.

ISSUE 1 - 22/09/2021 (NSY)

CONSUMER NOTICE

The catalogue description and any exhibition of samples are only broad indications of the Products and R&G may make design changes which do not diminish their performance or visual appeal and supplying them in such state shall conform to the order. The Buyer acknowledges no representation or warranty (other than as to title) has been given or will apply to the Products other than those in R&G's order or confirmation and the Buyer confirms it has chosen the Products as being of merchantable quality and suitable for its particular purposes. Where R&G fits the Products or undertakes other services it shall exercise reasonable skill and care and rectify any fault free of charge unless the workmanship has been disturbed. The Buyer is responsible for ensuring that the warranty on the motorcycle is not affected by the fitting of the Products. On return of any defective Products R&G shall at its option either supply a replacement or refund the purchase money but shall not be liable if the Products have been modified or used or maintained otherwise than in accordance with R&G's or manufacturer's instructions and good engineering practice or if the defect arises from accident or neglect. Other than identified above and subject to R&G not limiting its liability for causing death and personal injury, it shall not be liable for indirect or consequential loss and otherwise its liability shall be limited to the amounts paid by the Buyer for the Products or the fitting or service concerned. These terms do not affect the Buyer's statutory rights.

R&G RACING RETURNS POLICY (NON-FAULTY GOODS)

Returns must be pre-authorized (if not pre-authorized the return will be rejected). Goods may only be returned direct to us if they were purchased direct from us (customer must prove if necessary). Otherwise to be returned

R&G Racing

Unit 1, Shelley's Lane, East Worldham, Alton, Hampshire, GU34 3AQ

Tel: +44 (0)1420 89007 Fax: +44 (0)1420 87301 www.rg-racing.com Email: info@rg-racing.com



to original vendor. Goods must be in re-sellable condition, in the opinion of R&G Racing. All returns are subject to a 25% restocking and handling fee (25% of the gross value exc. P&P – at the prevailing price at time of purchase). The customer must pay any and all carriage charges. No returns of discontinued products, unless within 14 days of purchase. This policy does not affect your statutory rights and does not refer to faulty goods.

R&G Racing

Unit 1, Shelley's Lane, East Worldham, Alton, Hampshire, GU34 3AQ

Tel: +44 (0)1420 89007 Fax: +44 (0)1420 87301 www.rg-racing.com Email: info@rg-racing.com