

FITTING INSTRUCTIONS FOR CLIG0019



This Kit contains the items pictured and labelled over page.

Some parts may be shown for clarity of instructions only.

Do not proceed until you are sure all parts are present.

Please read all instructions before proceeding.

**IF IN ANY DOUBT WHEN FITTING OUR PRODUCTS, CONSULT ONE OF OUR DEALERS
OR HAVE FITTED BY A QUALIFIED TECHNICIAN.**

PLEASE NOTE THAT THE WAY THE KIT IS PACKED DOES NOT NECESSARILY REPRESENT THE WAY OF
MOUNTING TO THE BIKE.

IN THE EVENT OF RUBBER WASHERS BEING USED TO HOLD COMPONENTS ONTO BOLTS,
THESE RUBBER WASHERS CAN BE THROWN AWAY.

<u>TOOLS REQUIRED</u>	<u>GENERAL TORQUE SETTINGS</u>
<ul style="list-style-type: none"> • Set of Metric Allen keys. 	<p>M4 BOLT = 8Nm</p> <p>M5 BOLT = 12Nm</p> <p>M6 BOLT = 15Nm</p> <p>M8 BOLT = 20Nm</p> <p>M10 BOLT = 40Nm</p> <p>M12 BOLT = 40Nm</p>

LEGEND

ITEM No.	DESCRIPTION	QTY
ITEM 1	LEVER GUARD	1
ITEM 2	THREADED MOUNTING BLOCK	1
ITEM 3	M5 x 20mm BOLT	1
ITEM 4	M5 WASHER	1

ASSEMBLY DIAGRAM

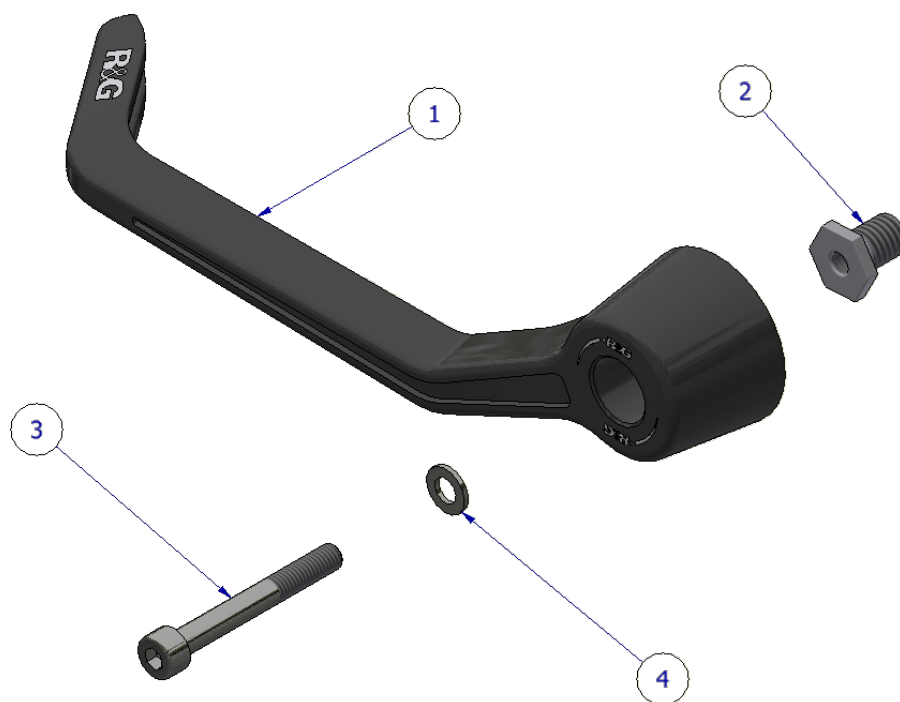

FITTING INSTRUCTIONS

- To fit the R&G Brake Lever Guard, you will need to remove the original bar-end using the specific tools to your bike. Place the M5 washer (**item 4**) over the M5 bolt (**item 3**), then slide through the brake lever guard (**item 1**) so the washer sits against the flat surface within the mounting bore.
- Wind the threaded block (**item 2**) into the handlebar end and fully tighten with a 13mm spanner/socket.
- Locate the lever guard assembly into the threaded block previously fitted and position so when the motorcycle is at full lock in both directions it does not contact any other part of the motorcycle.
- Using a 4mm Allen tool, fully tighten the bolt and check operation. Do not exceed 12Nm of torque.

IMPORTANT - WHEN FITTING THIS PRODUCT, IT IS YOUR RESPONSIBILITY TO ENSURE THAT THE PRODUCT IN NO WAY IMPEDES THE OPERATION OF THE MOTORCYCLE AND IS CHECKED REGULARLY FOR TIGHTNESS AND CORRECT OPERATION.

FAILURE TO CHECK THE ABOVE COULD RESULT IN SERIOUS INJURY OR DAMAGE.

ISSUE 1 – 19/03/2025 (MH)

CONSUMER NOTICE

The catalogue description and any exhibition of samples are only broad indications of the Products and R&G may make design changes which do not diminish their performance or visual appeal and supplying them in such state shall conform to the order. The Buyer acknowledges no representation or warranty (other than as to title) has been given or will apply to the Products other than those in R&G's order or confirmation and the Buyer confirms it has chosen the Products as being of merchantable quality and suitable for its particular purposes. Where R&G fits the Products or undertakes other services it shall exercise reasonable skill and care and rectify any fault free of charge unless the workmanship has been disturbed. The Buyer is responsible for ensuring that the warranty on the motorcycle is not affected by the fitting of the Products. On return of any defective Products R&G shall at its option either supply a replacement or refund the purchase money but shall not be liable if the Products have been modified or used or maintained otherwise than in accordance with R&G's or manufacturer's instructions and good engineering practice or if the defect arises from accident or neglect. Other than identified above and subject to R&G not limiting its liability for causing death and personal injury, it shall not be liable for indirect or consequential loss and otherwise its liability shall be limited to the amounts paid by the Buyer for the Products or the fitting or service concerned. These terms do not affect the Buyer's statutory rights.

R&G RACING RETURNS POLICY (NON-FAULTY GOODS)

Returns must be pre-authorized (if not pre-authorized the return will be rejected). Goods may only be returned direct to us if they were purchased direct from us (customer must prove if necessary). Otherwise to be returned to original vendor. Goods must be in re-sellable condition, in the opinion of R&G Racing. All returns are subject to a 25% restocking and handling fee (25% of the gross value exc. P&P – at the prevailing price at time of purchase). The customer must pay any and all carriage charges. No returns of discontinued products, unless within 14 days of purchase. This policy does not affect your statutory rights and does not refer to faulty goods.

NOTICE DE MONTAGE POUR CLIG0019



**CE KIT CONTIENT LES ARTICLES ILLUSTRÉS ET ÉTIQUETÉS SUR LA PAGE.
CERTAINES PIÈCES PEUVENT ÊTRE INDIQUÉES UNIQUEMENT POUR LA CLARTÉ DES
INSTRUCTIONS.**

NE PAS CONTINUER AVANT D'ÊTRE SÛR DE LA PRÉSENCE DE TOUTES LES PIÈCES.

VEUILLEZ LIRE TOUTES LES INSTRUCTIONS AVANT DE CONTINUER.

**EN CAS DE DOUTE LORS DE L'INSTALLATION DE NOS PRODUITS, CONSULTEZ UN DE NOS
REVENDEURS OU FAITES INSTALLER PAR UN TECHNICIEN QUALIFIÉ.**

VEUILLEZ NOTER QUE LA FAÇON DONT LE KIT EST EMBALLÉ NE REPRÉSENTE PAS
NÉCESSAIREMENT LE MODE DE MONTAGE SUR LE VÉLO.

EN CAS D'UTILISATION DE RONDELLES EN CAOUTCHOUC POUR MAINTENIR LES
COMPOSANTS SUR LES BOULONS, CES RONDELLES EN CAOUTCHOUC PEUVENT ÊTRE JETÉES.

<u>OUTILS REQUIS</u>	<u>VALEURS DE SERRAGE</u>
<ul style="list-style-type: none"> • Clés Allen 	BOULON M4 = 8Nm BOULON M5 = 12Nm BOULON M6 = 15Nm BOULON M8 = 20Nm BOULON M10 = 40Nm BOULON M12 = 40Nm

LÉGENDE

ARTICLE No.	DESCRIPTION	QTÉ
ARTICLE 1	PROTÈGE-LEVIER	1
ARTICLE 2	BLOC DE MONTAGE FILETÉ	1
ARTICLE 3	M5 x 20mm BOULON	1
ARTICLE 4	M5 RONDELLE	1

SCHEMA D'ENSEMBLE

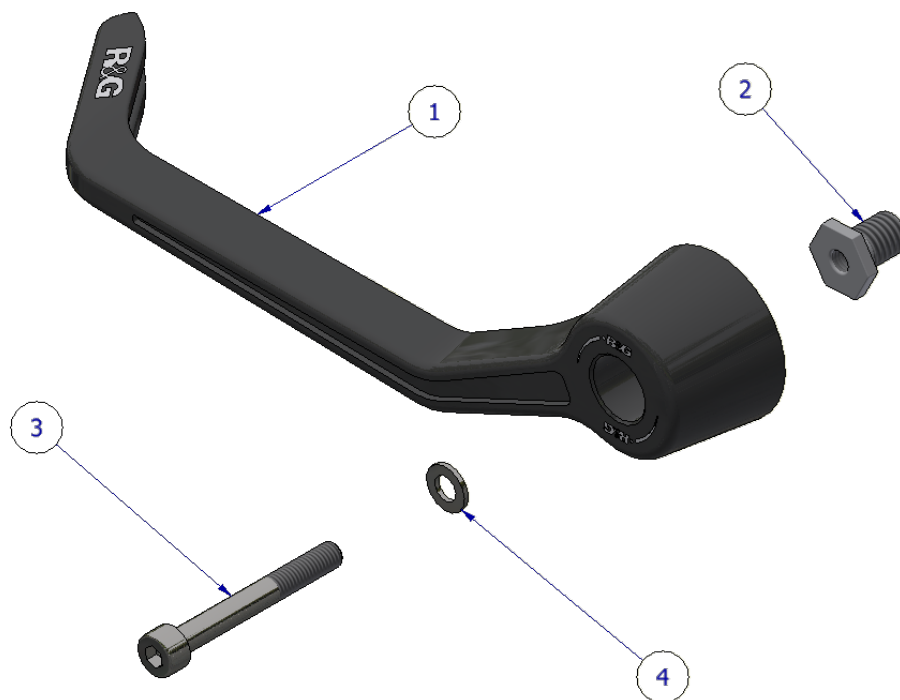

NOTICE DE MONTAGE

- Pour installer le protège-levier de frein R&G, vous devrez démonter l'embout de guidon d'origine à l'aide des outils spécifiques à votre moto. Placez la rondelle M5 (article 4) sur le boulon M5 (article 3), puis faites-la glisser à travers le protège-levier (article 1) de manière à ce que la rondelle repose contre la surface plane de l'alésage de montage.
- Insérez le bloc fileté (article 2) dans l'embout de guidon et serrez à fond avec une clé/douille de 13 mm.
- Insérez le protège-levier dans le bloc fileté précédemment installé et positionnez-la de manière à ce qu'il ne touche aucune autre pièce de la moto, lorsque la moto est braquée à fond dans les deux sens.
- À l'aide d'une clé Allen de 4 mm, serrez à fond le boulon et vérifiez le fonctionnement. Ne dépassez pas 12 Nm de couple.

IMPORTANT - LORS DE L'INSTALLATION DE CE PRODUIT, IL EST DE VOTRE RESPONSABILITÉ DE VOUS ASSURER QUE LE PRODUIT NE GÊNE EN AUCUN CAS LE FONCTIONNEMENT DE LA MOTO ET SOIT VÉRIFIÉ RÉGULIÈREMENT POUR SON SERRAGE ET SON BON FONCTIONNEMENT.

NE PAS VÉRIFIER LES ÉLÉMENTS CI-DESSUS PEUT ENTRAÎNER DES BLESSURES OU DES DOMMAGES GRAVES.

ISSUE 1 – 19/03/2025 (MH)

CONSUMER NOTICE

The catalogue description and any exhibition of samples are only broad indications of the Products and R&G may make design changes which do not diminish their performance or visual appeal and supplying them in such state shall conform to the order. The Buyer acknowledges no representation or warranty (other than as to title) has been given or will apply to the Products other than those in R&G's order or confirmation and the Buyer confirms it has chosen the Products as being of merchantable quality and suitable for its particular purposes. Where R&G fits the Products or undertakes other services it shall exercise reasonable skill and care and rectify any fault free of charge unless the workmanship has been disturbed. The Buyer is responsible for ensuring that the warranty on the motorcycle is not affected by the fitting of the Products. On return of any defective Products R&G shall at its option either supply a replacement or refund the purchase money but shall not be liable if the Products have been modified or used or maintained otherwise than in accordance with R&G's or manufacturer's instructions and good engineering practice or if the defect arises from accident or neglect. Other than identified above and subject to R&G not limiting its liability for causing death and personal injury, it shall not be liable for indirect or consequential loss and otherwise its liability shall be limited to the amounts paid by the Buyer for the Products or the fitting or service concerned. These terms do not affect the Buyer's statutory rights.

R&G RACING RETURNS POLICY (NON-FAULTY GOODS)

Returns must be pre-authorized (if not pre-authorized the return will be rejected). Goods may only be returned direct to us if they were purchased direct from us (customer must prove if necessary). Otherwise to be returned to original vendor. Goods must be in re-sellable condition, in the opinion of R&G Racing. All returns are subject to a 25% restocking and handling fee (25% of the gross value exc. P&P – at the prevailing price at time of purchase). The customer must pay any and all carriage charges. No returns of discontinued products, unless within 14 days of purchase. This policy does not affect your statutory rights and does not refer to faulty goods.