



**FITTING INSTRUCTIONS FOR ECC0094PRO**  
**LHS ENGINE CASE COVER PRO**



**HIS KIT CONTAINS THE ITEMS PICTURED AND LABELLED OVER PAGE.**

SOME PARTS MAY BE SHOWN FOR CLARITY OF INSTRUCTIONS ONLY.

DO NOT PROCEED UNTIL YOU ARE SURE ALL PARTS ARE PRESENT.

**PLEASE READ ALL INSTRUCTIONS BEFORE PROCEEDING.**

**IF IN ANY DOUBT WHEN FITTING OUR PRODUCTS, CONSULT ONE OF  
OUR DEALERS OR HAVE FITTED BY A QUALIFIED TECHNICIAN.**

**PLEASE BE AWARE THAT THE PLASTIC SKIDDER IS ASSEMBLED IN POSITION FOR  
PACKAGING PURPOSES ONLY. YOU WILL NEED TO REMOVE IT, PLACE 1 DROP OF  
BLUE THREAD LOCK TO EACH BOLT AND REASSEMBLE ONTO THE ALUMINIUM  
ENGINE CASE COVER. DO NOT EXCEED 15NM OF TORQUE.**

**DIGITAL COPIES OF THESE INSTRUCTIONS ARE AVAILABLE FROM:**

[WWW.RG-RACING.COM](http://WWW.RG-RACING.COM)



<b><u>TOOLS REQUIRED</u></b>	<b><u>GENERAL TORQUE SETTINGS</u></b>
<ul style="list-style-type: none"> <li>• Set of Metric Allen keys.</li> <li>• Metric Socket set.</li> <li>• Suitable Torque Wrench.</li> </ul>	<p>M6 BOLT = 15Nm  M8 BOLT = 20Nm  M10 BOLT = 40Nm  M12 BOLT = 40Nm</p>

### **LEGEND**

<b>ITEM NO.</b>	<b>DESCRIPTION</b>	<b>QTY</b>
ITEM 1	CECC0094PRO (R&G ALUMINIUM ENGINE CASE COVER)	1
ITEM 2	ECS0178 (HDPE SKIDDER)	1
ITEM 3	M6 x 1.00 x 45mm LONG CAP HEAD BOLT	4
ITEM 4	M6 x 12mm OD WASHER	4
ITEM 5	M5 x 0.80 x 10mm CSK BOLTS	4

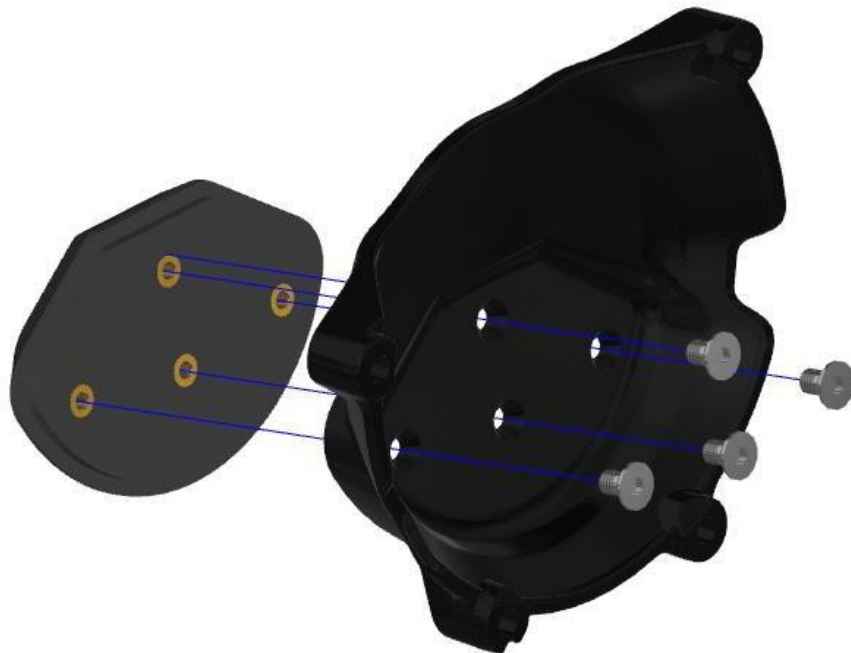

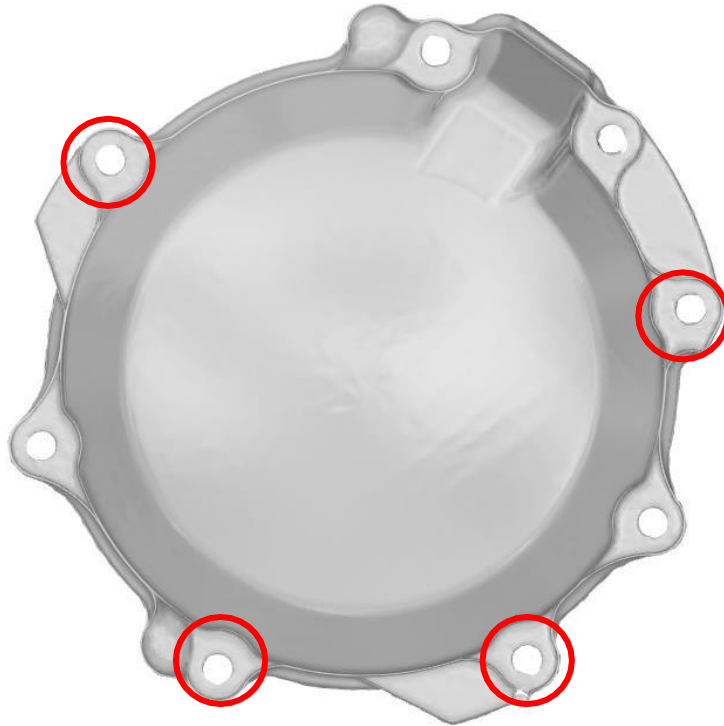

**PICTURE 1**



**PICTURE 2**



### **FITTING INSTRUCTIONS**

- Please make sure the engine is cold before proceeding with the fitting of the R&G cover.
- Remove the OEM engine case bolts as highlighted in **PICTURE 1**. DO NOT REMOVE ALL OF THE CASE BOLTS.
- Using the 4 x bolts (**ITEM 3**) and washers (**ITEM 4**) provided to secure **ITEM 1** as shown in **PICTURE 2**.
- With a 5mm hex bit tighten the bolts equally so that they pull the cover into place. DO NOT FULLY TIGHTEN.
- Finally use a torque wrench set at 10 N/m (7 Lb/ft) to fully tighten.
- It is suggested that you check the tightness of the mounting bolts on a regular basis i.e., when cleaning or once a month.
- R&G will accept no liability if the above procedure and torque settings are not followed.

### **SKIDDER REPLACEMENT**

If your skidder is showing signs of wear and needs replacing, please follow the following steps:

- Remove the 4 x CSK bolts (**ITEM 5**) from the reverse side of engine case cover, this will allow the skidder to be separated from the engine case cover.
- Slot the replacement skidder into the skidder shaped recess on the front of the engine case cover and secure using 4 x CSK bolts supplied with the replacement skidder as shown on **Page 2** of this document.

**See more R&G products for your Motorcycle in the link below:**  
[R&G Racing | All Products for Kawasaki - ZX10-R \(2020\) \(rg-racing.com\)](https://www.rg-racing.com)

ISSUE 2 – 14/05/2024 (MH)

#### **CONSUMER NOTICE**

The catalogue description and any exhibition of samples are only broad indications of the Products and R&G may make design changes which do not diminish their performance or visual appeal and supplying them in such state shall conform to the order. The Buyer acknowledges no representation or warranty (other than as to title) has been given or will apply to the Products other than those in R&G's order or confirmation and the Buyer confirms it has chosen the Products as being of merchantable quality and suitable for its particular purposes. Where R&G fits the Products or undertakes other services it shall exercise reasonable skill and care and rectify any fault free of charge unless the workmanship has been disturbed. The Buyer is responsible for ensuring that the warranty on the motorcycle is not affected by the fitting of the Products. On return of any defective Products R&G shall at its option either supply a replacement or refund the purchase money but shall not be liable if the Products have been modified or used or maintained otherwise than in accordance with R&G's or manufacturer's instructions and good engineering practice or if the defect arises from accident or neglect. Other than identified above and subject to R&G not limiting its liability for causing death and personal injury, it shall not be liable for indirect or consequential loss and otherwise its liability shall be limited to the amounts paid by the Buyer for the Products or the fitting or service concerned. These terms do not affect the Buyer's statutory rights.

#### **R&G RETURNS POLICY (NON-FAULTY GOODS)**

Returns must be pre-authorized (if not pre-authorized the return will be rejected). Goods may only be returned direct to us if they were purchased direct from us (customer must prove if necessary). Otherwise to be



returned to original vendor. Goods must be in re-sellable condition, in the opinion of R&G. All returns are subject to a 25% restocking and handling fee (25% of the gross value exc. P&P – at the prevailing price at time of purchase). The customer must pay any and all carriage charges. No returns of discontinued products, unless within 14 days of purchase. This policy does not affect your statutory rights and does not refer to faulty goods.



**NOTICE DE MONTAGE POUR ECC0094PRO**  
**PROTECTION CARTER MOTEUR PRO CÔTÉ GAUCHE**



**CE KIT CONTIENT LES ARTICLES ILLUSTRÉS ET ÉTIQUETES SUR LA PAGE.**  
CERTAINES PARTIES PEUVENT ÊTRE PRÉSENTES UNIQUEMENT POUR LA CLARTE DES  
INSTRUCTIONS.

NE PAS PROCÉDER AU MONTAGE TANT QUE VOUS N'ÊTES PAS SÛR QUE TOUTES LES PIÈCES  
SOIENT PRÉSENTES.

**VEUILLEZ LIRE TOUTES LES INSTRUCTIONS AVANT DE CONTINUER.**

**EN CAS DE DOUTE LORS DU MONTAGE DE NOS PRODUITS, CONSULTEZ  
UN DE NOS REVENDUEURS OU FAITES APPEL À UN TECHNICIEN  
QUALIFIÉ.**

VEUILLEZ NOTER QUE LA FAÇON DONT LE KIT EST EMBALLÉ NE REPRÉSENTE PAS  
NECESSAIREMENT LA MANIÈRE DE LE MONTER SUR LA MOTO.

SI DES RONDELLES EN CAOUTCHOUC SONT UTILISÉES POUR MAINTENIR LES COMPOSANTS  
SUR LES BOULONS, ELLES PEUVENT ÊTRE JETÉES.

**NOTICE DISPONIBLE AU TÉLÉCHARGEMENT SUR :**

[WWW.RG-RACING.COM](http://WWW.RG-RACING.COM)



<b><u>OUTILS REQUIS</u></b>	<b><u>VALEURS DE SERRAGE</u></b>
<ul style="list-style-type: none"> <li>• Clés Allen.</li> <li>• Clé métrique.</li> <li>• Clé dynamométrique.</li> </ul>	<p>M6 BOULON = 15Nm</p> <p>M8 BOULON = 20Nm</p> <p>M10 BOULON = 40Nm</p> <p>M12 BOULON = 40Nm</p>

## **LÉGENDE**

<b>ARTICLE NO.</b>	<b>DESCRIPTION</b>	<b>QTÉ</b>
ARTICLE 1	CECC0094PRO (PROTECTION CARTER MOTEUR R&G EN ALUMINIUM)	1
ARTICLE 2	ECS0178 (HDPE PROTECTION CADRE)	1
ARTICLE 3	M6 x 1.00 x 45mm BOULON	4
ARTICLE 4	M6 x 12mm RONDELLE	4
ARTICLE 5	M5 x 0.80 x 10mm BOULONS	4

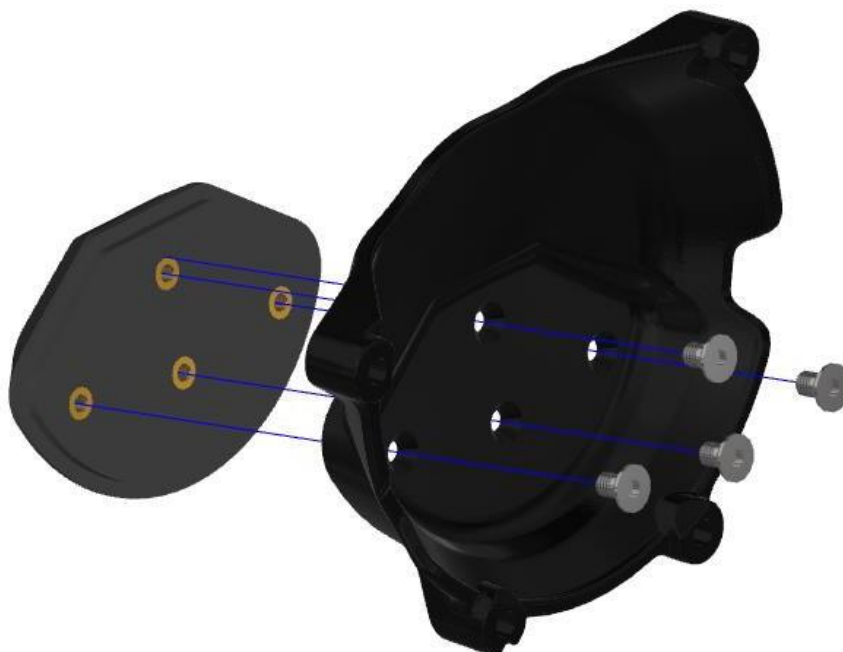

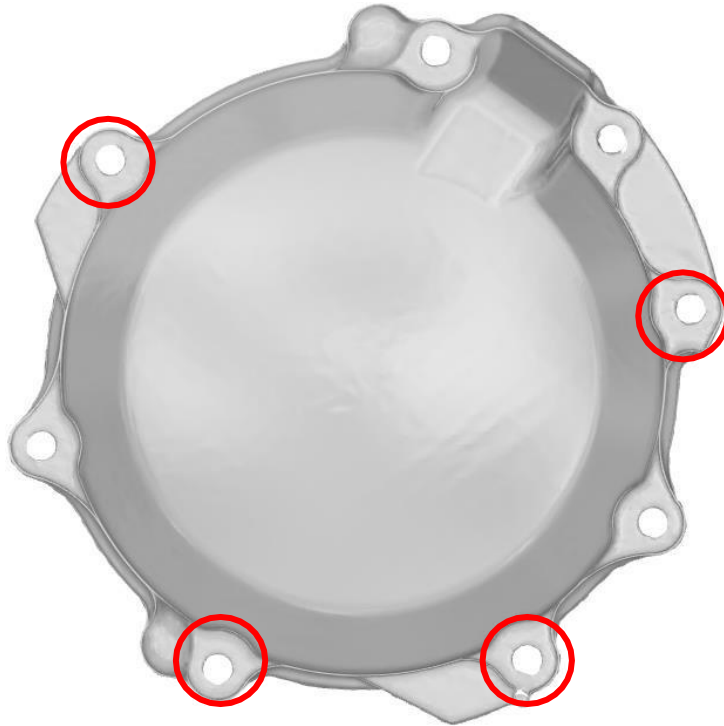

**PHOTO 1**



**PHOTO 2**



### **NOTICE DE MONTAGE**

- Assurez-vous que le moteur soit froid avant de procéder au montage du couvercle R&G.
- Retirez les boulons du carter du moteur d'origine comme indiqué sur la PHOTO 1. N'ENLEVEZ PAS TOUS LES BOULONS DU CARTER.
- Utiliser les 4 x boulons (ARTICLE 3) et rondelles (ARTICLE 4) fournis pour fixer l'ARTICLE 1 comme indiqué sur la PHOTO 2.
- À l'aide d'un embout hexagonal de 5 mm, serrez les boulons de manière égale afin qu'ils mettent le couvercle en place. NE PAS SERRER COMPLÈTEMENT.
- Enfin, utilisez une clé dynamométrique réglée à 10 N/m (7 Lb/ft) pour serrer complètement.
- Il est suggéré de vérifier régulièrement le serrage des boulons de montage, c'est-à-dire lors du nettoyage ou une fois par mois.
- R&G décline toute responsabilité si la procédure ci-dessus et les réglages de couple ne sont pas suivis.

### **REPLACEMENT DE LA PROTECTION CADRE**

Si votre protection montre des signes d'usure et doit être remplacé, veuillez suivre les étapes suivantes :

- Retirez les 4 boulons CSK (ARTICLE 5) de l'arrière du couvercle du carter moteur, cela permettra à la protection d'être séparé du couvercle du carter moteur.
- Insérez la plaque de rechange dans l'évidement à l'avant du couvercle du carter moteur et fixez-le à l'aide des 4 boulons CSK fournis avec la plaque de rechange, comme indiqué à la page 2 de ce document.

**Voir plus de produits R&G pour votre moto via ce lien :**  
[R&G Racing | All Products for Kawasaki - ZX10-R \(2020\) \(rg-racing.com\)](http://www.rg-racing.com)

ISSUE 1 29/03/2023 (AO)

#### **CONSUMER NOTICE**

The catalogue description and any exhibition of samples are only broad indications of the Products and R&G may make design changes which do not diminish their performance or visual appeal and supplying them in such state shall conform to the order. The Buyer acknowledges no representation or warranty (other than as to title) has been given or will apply to the Products other than those in R&G's order or confirmation and the Buyer confirms it has chosen the Products as being of merchantable quality and suitable for its particular purposes. Where R&G fits the Products or undertakes other services it shall exercise reasonable skill and care and rectify any fault free of charge unless the workmanship has been disturbed. The Buyer is responsible for ensuring that the warranty on the motorcycle is not affected by the fitting of the Products. On return of any defective Products R&G shall at its option either supply a replacement or refund the purchase money but shall not be liable if the Products have been modified or used or maintained otherwise than in accordance with R&G's or manufacturer's instructions and good engineering practice or if the defect arises from accident or neglect. Other than identified above and subject to R&G not limiting its liability for causing death and personal injury, it shall not be liable for indirect or consequential loss and otherwise its liability shall be limited to the amounts paid by the Buyer for the Products or the fitting or service concerned. These terms do not affect the Buyer's statutory rights.

**R&G RETURNS POLICY (NON-FAULTY GOODS)**

Returns must be pre-authorized (if not pre-authorized the return will be rejected). Goods may only be returned direct to us if they were purchased direct from us (customer must prove if necessary). Otherwise to be returned to original vendor. Goods must be in re-sellable condition, in the opinion of R&G. All returns are subject to a 25% restocking and handling fee (25% of the gross value exc. P&P - at the prevailing price at time of purchase). The customer must pay any and all carriage charges. No returns of discontinued products, unless within 14 days of purchase. This policy does not affect your statutory rights and does not refer to faulty goods.

**FITTING INSTRUCTIONS FOR ECC0095PRO RHS CLUTCH CASE COVER****PICTURE A**

**THIS KIT CONTAINS THE ITEMS PICTURED AND LABELLED OVER PAGE.**

SOME PARTS MAY BE SHOWN FOR CLARITY OF INSTRUCTIONS ONLY.

DO NOT PROCEED UNTIL YOU ARE SURE ALL PARTS ARE PRESENT.

**PLEASE READ ALL INSTRUCTIONS BEFORE PROCEEDING.**

**IF IN ANY DOUBT WHEN FITTING OUR PRODUCTS, CONSULT ONE OF OUR DEALERS OR HAVE FITTED BY A QUALIFIED TECHNICIAN.**

**PLEASE BE AWARE THAT THE PLASTIC SKIDDER IS ASSEMBLED IN POSITION FOR PACKAGING PURPOSES ONLY. YOU WILL NEED TO REMOVE IT, PLACE 1 DROP OF**



**BLUE THREAD LOCK TO EACH BOLT AND REASSEMBLE ONTO THE ALUMINIUM ENGINE CASE COVER. DO NOT EXCEED 15Nm OF TORQUE.**

**DIGITAL COPIES OF THESE INSTRUCTIONS ARE AVAILABLE FROM:**

[WWW.RG-RACING.COM](http://WWW.RG-RACING.COM)

<b><u>TOOLS REQUIRED</u></b>	<b><u>GENERAL TORQUE SETTINGS</u></b>
<ul style="list-style-type: none"> <li>• Set of metric Allen keys to include 5mm A/F.               <ul style="list-style-type: none"> <li>• 8mm Socket and wrench.</li> <li>• Suitable Torque Wrench.</li> </ul> </li> </ul>	<p>M4 BOLT = 8Nm            M5 BOLT = 12Nm            M6 BOLT = 15Nm            M8 BOLT = 20Nm            M10 BOLT = 40Nm            M12 BOLT = 40Nm</p>

### **LEGEND**

<b>ITEM NO.</b>	<b>DESCRIPTION</b>	<b>QTY</b>
ITEM 1	R&G CLUTCH CASE COVER WITH SPACERS FITTED (PC0095BK)	1
ITEM 2	11mm SPACER	1
ITEM 3	22mm SPACER	1
ITEM 4	39.5mm SPACER	1
ITEM 5	M6 x 40mm BOLT	1
ITEM 6	M6 x 50mm BOLT	1
ITEM 7	M6 x 70mm BOLT	1

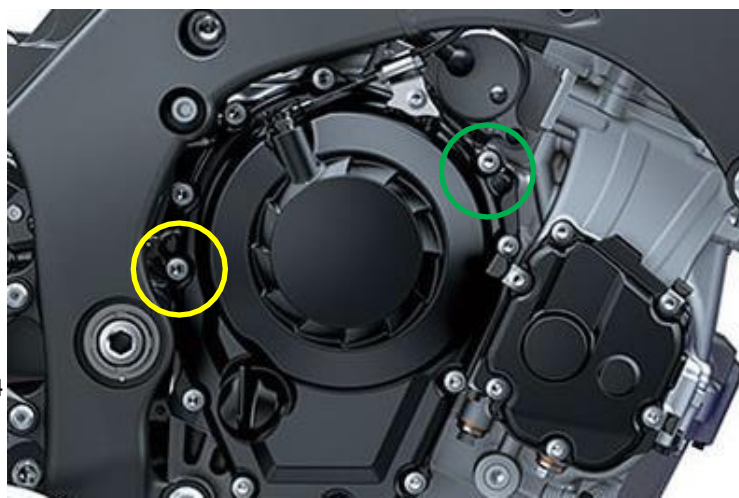

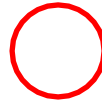

PICTURE 1

### **FITTING INSTRUCTIONS**

- Please ensure the engine is cold before proceeding with the fitment of the R&G engine case cover.
- Remove the right-hand side fairing.
- Remove the three bolts arrowed in **picture 1**, hold the cover up to the casing to identify the correct bolts. **DO NOT REMOVE ALL THE ENGINE CASE BOLTS.**
- Offer the R&G cover up to the engine case and carefully fit over the casing. Please ensure that the three bolt holes in the cover are aligned with the holes in the engine case.
- Fit the specified bolts through the cover and spacers into the engine case:
  - YELLOW – 70mm bolt & 39.5mm spacer
  - RED – 40mm bolt & 11mm spacer
  - GREEN – 50mm bolt & 22mm spacer
- Using a 5mm Allen key or socket bit tighten the bolts evenly to pull the cover into position. **DO NOT FULLY TIGHTEN AT THIS STAGE.**
- Finally use a torque wrench set at 10 N/m (7lb/ft) to fully tighten.
- It is suggested that you check the tightness of the mounting bolts after the first heat cycle and then on a regular basis i.e. - when cleaning or once a month.
- R&G will accept no liability if the above procedures and torque setting are not followed.

ISSUE 2 – 14/05/2024 (MH)

### **CONSUMER NOTICE**

The catalogue description and any exhibition of samples are only broad indications of the Products and R&G may make design changes which do not diminish their performance or visual appeal and supplying them in such state shall conform to the order. The Buyer acknowledges no representation or warranty (other than as to title) has been given or will apply to the Products other than those in R&G's order or confirmation and the Buyer confirms it has chosen the Products as being of merchantable quality and suitable for its particular purposes. Where R&G fits the Products or undertakes other services it shall exercise reasonable skill and care and rectify any fault free of charge unless the workmanship has been disturbed. The Buyer is responsible for ensuring that the warranty on the motorcycle is not affected by the fitting of the Products. On return of any defective Products R&G shall at its option either supply a replacement or refund the purchase money but shall not be liable if the Products have been modified or used or maintained otherwise than in accordance with R&G's or manufacturer's instructions and good engineering practice or if the defect arises from accident or neglect. Other than identified above and subject to R&G not limiting its liability for causing death and personal injury, it shall not be liable for indirect or consequential loss and otherwise its liability shall be limited to the amounts paid by the Buyer for the Products or the fitting or service concerned. These terms do not affect the Buyer's statutory rights.

**R&G RETURNS POLICY (NON-FAULTY GOODS)**

Returns must be pre-authorized (if not pre-authorized the return will be rejected). Goods may only be returned direct to us if they were purchased direct from us (customer must prove if necessary). Otherwise to be returned to original vendor. Goods must be in re-sellable condition, in the opinion of R&G. All returns are subject to a 25% restocking and handling fee (25% of the gross value exc. P&P - at the prevailing price at time of purchase). The customer must pay any and all carriage charges. No returns of discontinued products, unless within 14 days of purchase. This policy does not affect your statutory rights and does not refer to faulty goods.

**NOTICE DE MONTAGE POUR ECC0095PRO PROTECTION CARTER  
MOTEUR CÔTÉ DROIT****PHOTO A**

**CE KIT CONTIENT LES ARTICLES ILLUSTRÉS ET ÉTIQUETES SUR LA PAGE.**  
CERTAINES PARTIES PEUVENT ÊTRE PRÉSENTES UNIQUEMENT POUR LA CLARTE DES  
INSTRUCTIONS.

NE PAS PROCÉDER AU MONTAGE TANT QUE VOUS N'ÊTES PAS SÛR QUE TOUTES LES PIÈCES  
SOIENT PRÉSENTES.

**VEUILLEZ LIRE TOUTES LES INSTRUCTIONS AVANT DE CONTINUER.**



**EN CAS DE DOUTE LORS DU MONTAGE DE NOS PRODUITS, CONSULTEZ  
UN DE NOS REVENDEURS OU FAITES APPEL A UN TECHNICIEN  
QUALIFIÉ.**

VEUILLEZ NOTER QUE LA FAÇON DONT LE KIT EST EMBALLE NE REPRESENTE PAS  
NECESSAIREMENT LA MANIERE DE LE MONTER SUR LA MOTO.

SI DES RONDELLES EN CAOUTCHOUC SONT UTILISEES POUR MAINTENIR LES COMPOSANTS  
SUR LES BOULONS, ELLES PEUVENT ETRE JETEES.

**NOTICE DISPONIBLE AU TELECHARGEMENT SUR :**  
[WWW.RG-RACING.COM](http://WWW.RG-RACING.COM)

<b><u>OUTILS REQUIS</u></b>	<b><u>VALEURS DE SERRAGE</u></b>
<ul style="list-style-type: none"> <li>• Clés Allen 5mm</li> <li>• Clé à cliquet + douille 8mm</li> <li>• Clé dynamométrique</li> </ul>	M4 BOULON = 8Nm M5 BOULON = 12Nm M6 BOULON = 15Nm M8 BOULON = 20Nm M10 BOULON = 40Nm M12 BOULON = 40Nm

## **LÉGENDE**

<b>ARTICLE NO.</b>	<b>DESCRIPTION</b>	<b>QTÉ</b>
ARTICLE 1	PROTECTION CARTER MOTEUR R&G (PC0095BK)	1
ARTICLE 2	11mm ENTRETOISE	1
ARTICLE 3	22mm ENTRETOISE	1
ARTICLE 4	39.5mm ENTRETOISE	1
ARTICLE 5	M6 x 40mm BOULON	1
ARTICLE 6	M6 x 50mm BOULON	1
ARTICLE 7	M6 x 70mm BOULON	1



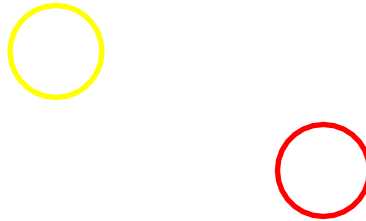

PHOTO 1  
**NOTICE DE MONTAGE**

- Veuillez-vous assurer que le moteur soit froid avant de procéder au montage de la protection carter moteur R&G.
- Déposer le carénage latéral droit.
- Retirez les trois boulons fléchés sur la photo 1, maintenez le couvercle contre le boîtier pour identifier les bons trous. **NE RETIREZ PAS TOUS LES BOULONS DU CARTER MOTEUR.**
- Présentez le couvercle R&G sur le carter moteur et placez-le soigneusement sur le carter. Veuillez-vous assurer que les trois trous de boulons du couvercle soient alignés avec les trous du carter moteur.
- Insérez les boulons spécifiés à travers le couvercle et les entretoises dans le carter moteur :
  - JAUNE – 70mm boulon & 39.5mm entretoise
  - ROUGE – 40mm boulon & 11mm entretoise
  - VERT – 50mm boulon & 22mm entretoise
- À l'aide d'une clé Allen 5mm, serrez les boulons uniformément pour mettre le couvercle en position. **NE SERREZ PAS COMPLÈTEMENT À CE STADE.**
- Enfin, utilisez une clé dynamométrique réglée à 10 N/m (7lb/ft) pour serrer complètement.
- Il est suggéré de vérifier le serrage des boulons de fixation lors du nettoyage ou une fois par mois.
- R&G n'acceptera aucune responsabilité si **les procédures ci-dessus et le réglage du couple ne sont pas suivis.**

ISSUE 1 – 13/11/2023 (MH)



**FITTING INSTRUCTIONS FOR ECC0312PRO**  
**RHS PULSE CASE COVER**



**THIS KIT CONTAINS THE ITEMS PICTURED AND LABELLED OVER PAGE.**  
SOME PARTS MAY BE SHOWN FOR CLARITY OF INSTRUCTIONS ONLY.

DO NOT PROCEED UNTIL YOU ARE SURE ALL PARTS ARE PRESENT.

**PLEASE READ ALL INSTRUCTIONS BEFORE PROCEEDING.**

**IF IN ANY DOUBT WHEN FITTING OUR PRODUCTS, CONSULT ONE OF  
OUR DEALERS OR HAVE FITTED BY A QUALIFIED TECHNICIAN.**

**PLEASE BE AWARE THAT THE PLASTIC SKIDDER IS ASSEMBLED IN POSITION FOR  
PACKAGING PURPOSES ONLY. YOU WILL NEED TO REMOVE IT, PLACE 1 DROP OF  
BLUE THREAD LOCK TO EACH BOLT AND REASSEMBLE ONTO THE ALUMINIUM  
ENGINE CASE COVER. DO NOT EXCEED 15NM OF TORQUE.**



**DIGITAL COPIES OF THESE INSTRUCTIONS ARE AVAILABLE FROM:**

[WWW.RG-RACING.COM](http://WWW.RG-RACING.COM)

<b><u>TOOLS REQUIRED</u></b>	<b><u>GENERAL TORQUE SETTINGS</u></b>
<ul style="list-style-type: none"> <li>• Set of Metric Allen keys.</li> <li>• Metric Socket set.</li> <li>• Suitable Torque Wrench.</li> </ul>	<p>M4 BOLT = 8Nm</p> <p>M5 BOLT = 12Nm</p> <p>M6 BOLT = 15Nm</p> <p>M8 BOLT = 20Nm</p> <p>M10 BOLT = 40Nm</p> <p>M12 BOLT = 40Nm</p>

**LEGEND**

<b>ITEM NO.</b>	<b>DESCRIPTION</b>	<b>QTY</b>
ITEM 1	CECC0096PRO (R&G ALUMINIUM ENGINE CASE COVER)	1
ITEM 2	ECS0183 (SKIDDER ASSEMBLY)	1
ITEM 3	M6 x 1.00 x 45mm CAP HEAD BOLT	4
ITEM 4	M6 x 12MM OD WASHER	4
ITEM 5	M5 x 0.80 x 10mm CSK BOLTS	4

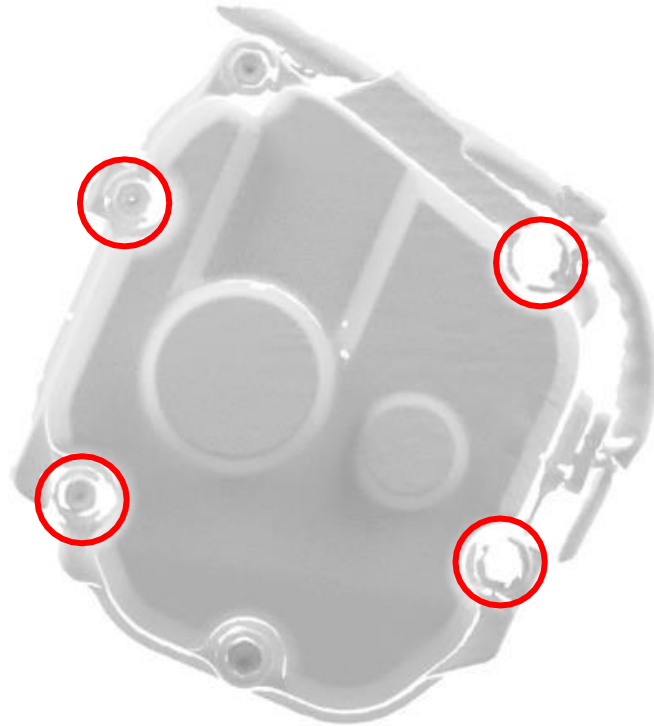

**PICTURE 1**

**PICTURE 2****FITTING INSTRUCTIONS**

- Ensure the skidder (**ITEM 2**) is fitted securely to the Engine Case Cover (**ITEM 1**) using the 4 x countersunk bolts (**ITEM 5**).
- Please make sure the engine is cold before proceeding with the fitting of the R&G cover.
- Remove the OEM engine case bolts as highlighted in **PICTURE 1. DO NOT REMOVE ALL OF THE CASE BOLTS.**
- Following the guide on **Picture 2**, Using the 4 x bolts (**ITEM 3**) and washers (**ITEM 4**) provided to secure the engine case cover to the bike.
- With a 5MM hex tool, tighten the bolts equally so that they pull the cover into place. **DO NOT FULLY TIGHTEN.**
- Finally use a torque wrench set at 10 N/m (7 Lb/ft) to fully tighten.
- It is suggested that you check the tightness of the mounting bolts on a regular basis such as when cleaning or once a month.
- R&G will accept no liability if the above procedure and torque settings are not followed.

ISSUE 2 - 14/05/2024 (MH)



#### **CONSUMER NOTICE**

The catalogue description and any exhibition of samples are only broad indications of the Products and R&G may make design changes which do not diminish their performance or visual appeal and supplying them in such state shall conform to the order. The Buyer acknowledges no representation or warranty (other than as to title) has been given or will apply to the Products other than those in R&G's order or confirmation and the Buyer confirms it has chosen the Products as being of merchantable quality and suitable for its particular purposes. Where R&G fits the Products or undertakes other services it shall exercise reasonable skill and care and rectify any fault free of charge unless the workmanship has been disturbed. The Buyer is responsible for ensuring that the warranty on the motorcycle is not affected by the fitting of the Products. On return of any defective Products R&G shall at its option either supply a replacement or refund the purchase money but shall not be liable if the Products have been modified or used or maintained otherwise than in accordance with R&G's or manufacturer's instructions and good engineering practice or if the defect arises from accident or neglect. Other than identified above and subject to R&G not limiting its liability for causing death and personal injury, it shall not be liable for indirect or consequential loss and otherwise its liability shall be limited to the amounts paid by the Buyer for the Products or the fitting or service concerned. These terms do not affect the Buyer's statutory rights.

#### **R&G RETURNS POLICY (NON-FAULTY GOODS)**

Returns must be pre-authorized (if not pre-authorized the return will be rejected). Goods may only be returned direct to us if they were purchased direct from us (customer must prove if necessary). Otherwise to be returned to original vendor. Goods must be in re-sellable condition, in the opinion of R&G. All returns are subject to a 25% restocking and handling fee (25% of the gross value exc. P&P – at the prevailing price at time of purchase). The customer must pay any and all carriage charges. No returns of discontinued products, unless within 14 days of purchase. This policy does not affect your statutory rights and does not refer to faulty goods.