

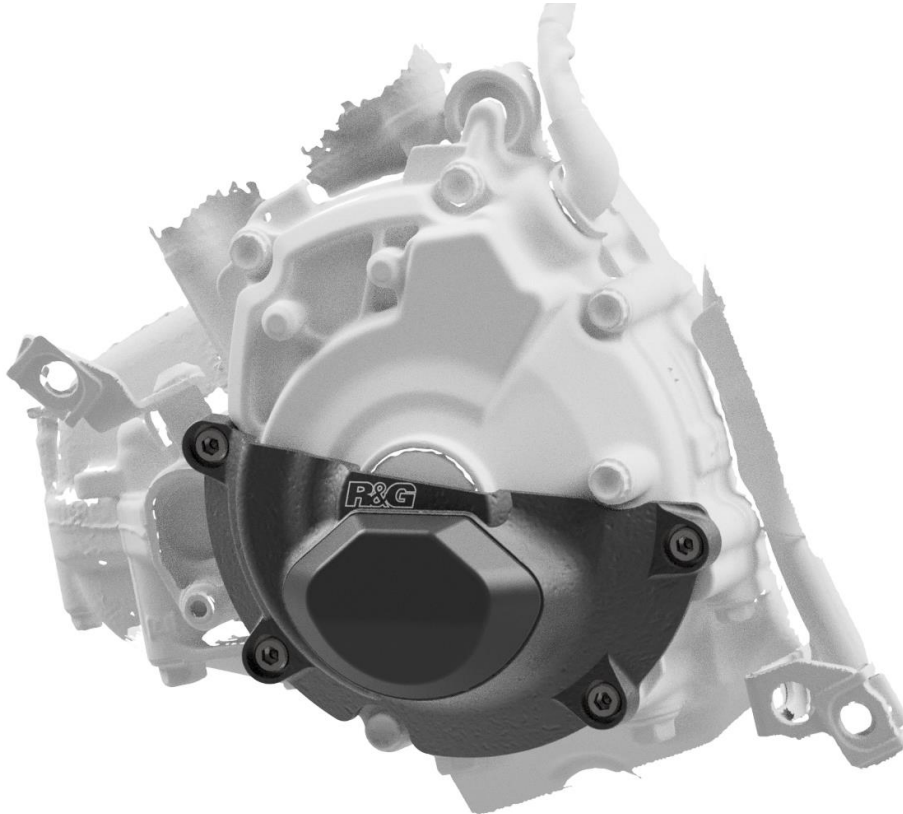

**FITTING INSTRUCTIONS FOR ECC0400PRO**  
**LHS ENGINE CASE COVER**



**THIS KIT CONTAINS THE ITEMS PICTURED AND LABELLED OVER PAGE.**  
SOME PARTS MAY BE SHOWN FOR CLARITY OF INSTRUCTIONS ONLY.

DO NOT PROCEED UNTIL YOU ARE SURE ALL PARTS ARE PRESENT.

**PLEASE READ ALL INSTRUCTIONS BEFORE PROCEEDING.**

**IF IN ANY DOUBT WHEN FITTING OUR PRODUCTS, CONSULT ONE OF OUR DEALERS  
OR HAVE FITTED BY A QUALIFIED TECHNICIAN.**

**PLEASE BE AWARE THAT THE PLASTIC SKIDDER IS ASSEMBLED IN POSITION FOR PACKAGING  
PURPOSES ONLY. YOU WILL NEED TO REMOVE IT, PLACE 1 DROP OF BLUE THREAD LOCK TO  
EACH BOLT AND REASSEMBLE ONTO THE ALUMINIUM ENGINE CASE COVER. DO NOT EXCEED  
15NM OF TORQUE.**

**DIGITAL COPIES OF THESE INSTRUCTIONS ARE AVAILABLE FROM:**

[WWW.RG-RACING.COM](http://WWW.RG-RACING.COM)

R&G  
Unit 1, Shelley's Lane, East Worldham, Alton, Hampshire, GU34 3AQ  
Tel: +44 (0)1420 89007 Fax: +44 (0)1420 87301 [www.rg-racing.com](http://www.rg-racing.com) Email: [info@rg-racing.com](mailto:info@rg-racing.com)



<b><u>TOOLS REQUIRED</u></b>	<b><u>GENERAL TORQUE SETTINGS</u></b>
<ul style="list-style-type: none"> <li>• Set of Metric Allen keys.</li> <li>• Metric Socket set.</li> <li>• Suitable Torque Wrench.</li> </ul>	<p>M4 BOLT = 8Nm</p> <p>M5 BOLT = 12Nm</p> <p>M6 BOLT = 15Nm</p> <p>M8 BOLT = 20Nm</p> <p>M10 BOLT = 40Nm</p> <p>M12 BOLT = 40Nm</p>

### **LEGEND**

<b>ITEM NO.</b>	<b>DESCRIPTION</b>	<b>QTY</b>
ITEM 1	CECC0400PRO (R&G ALUMINIUM ENGINE CASE COVER)	1
ITEM 2	ECS0183 (SKIDDER ASSEMBLY)	1
ITEM 3	M6 x 1.00 x 30mm CAP HEAD BOLTS	4
ITEM 4	M6 x 12mm O/D WASHER	4
ITEM 5	M5 x 0.80 x 10mm CSK BOLTS	4

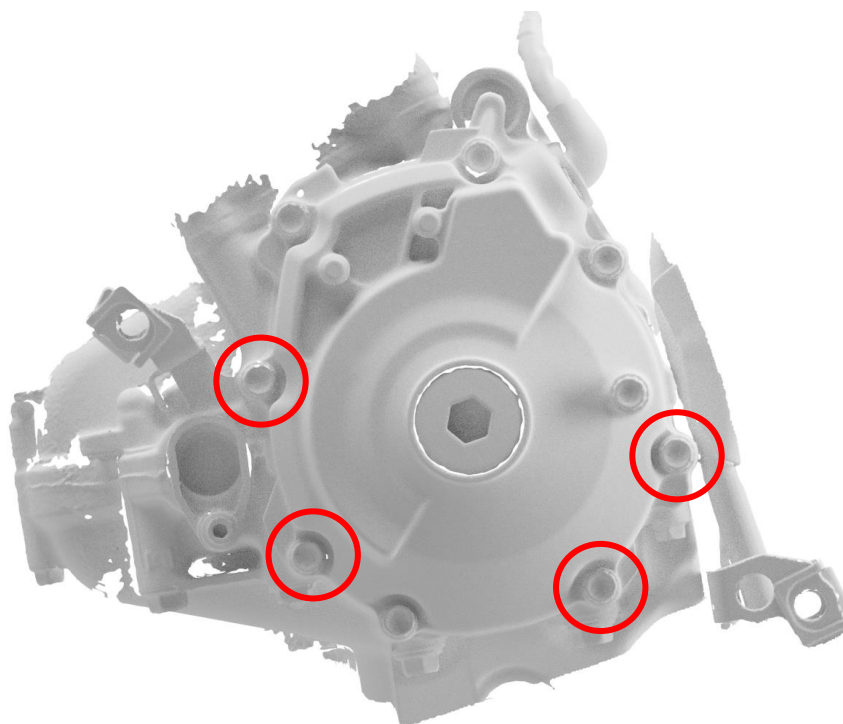

**PICTURE 1**



### **FITTING INSTRUCTIONS**

- Please make sure the engine is cold before proceeding with the fitting of the R&G cover.
- Remove the OEM engine case bolts as highlighted in **PICTURE 1**. DO NOT REMOVE ALL OF THE CASE BOLTS.
- Place an M6 washer (**Item 4**) over each of the provided bolts.
- Use the 4x M6 bolts (**Item 3**) provided to secure the engine case cover to the case.
- With a socket wrench tighten the bolts equally so that they pull the cover into place. DO NOT FULLY TIGHTEN.
- Finally use a torque wrench set at 10 N/m (7 Lb/ft) to fully tighten.
- It is suggested that you check the tightness of the mounting bolts on a regular basis such as when cleaning or once a month.
- R&G will accept no liability if the above procedure and torque settings are not followed.

### **SKIDDER REPLACEMENT**

If your skidder is showing signs of wear and needs replacing, please follow the following steps:

- Remove the 4 x CSK bolts (**Item 5**) from the reverse side of engine case cover, this will allow the skidder to be separated from the engine case cover.
- Slot the replacement skidder into the skidder shaped recess on the front of the engine case cover and secure using 4 x CSK bolts supplied with the replacement skidder.

ISSUE 2 – 14/05/2024 (MH)

### **CONSUMER NOTICE**

The catalogue description and any exhibition of samples are only broad indications of the Products and R&G may make design changes which do not diminish their performance or visual appeal and supplying them in such state shall conform to the order. The Buyer acknowledges no representation or warranty (other than as to title) has been given or will apply to the Products other than those in R&G's order or confirmation and the Buyer confirms it has chosen the Products as being of merchantable quality and suitable for its particular purposes. Where R&G fits the Products or undertakes other services it shall exercise reasonable skill and care and rectify any fault free of charge unless the workmanship has been disturbed. The Buyer is responsible for ensuring that the warranty on the motorcycle is not affected by the fitting of the Products. On return of any defective Products R&G shall at its option either supply a replacement or refund the purchase money but shall not be liable if the Products have been modified or used or maintained otherwise than in accordance with R&G's or manufacturer's instructions and good engineering practice or if the defect arises from accident or neglect. Other than identified above and subject to R&G not limiting its liability for causing death and personal injury, it shall not be liable for indirect or consequential loss and otherwise its liability shall be limited to the amounts paid by the Buyer for the Products or the fitting or service concerned. These terms do not affect the Buyer's statutory rights.

### **R&G RETURNS POLICY (NON-FAULTY GOODS)**

Returns must be pre-authorized (if not pre-authorized the return will be rejected). Goods may only be returned direct to us if they were purchased direct from us (customer must prove if necessary). Otherwise to be returned to original vendor. Goods must be in re-sellable condition, in the opinion of R&G. All returns are subject to a 25% restocking and handling fee (25% of the gross value exc. P&P – at the prevailing price at time of purchase). The customer must pay any and all carriage charges. No returns of discontinued products, unless within 14 days of purchase. This policy does not affect your statutory rights and does not refer to faulty goods.

R&G

Unit 1, Shelley's Lane, East Worldham, Alton, Hampshire, GU34 3AQ

Tel: +44 (0)1420 89007 Fax: +44 (0)1420 87301 [www.rg-racing.com](http://www.rg-racing.com) Email: [info@rg-racing.com](mailto:info@rg-racing.com)



**FITTING INSTRUCTIONS FOR ECC0401PRO**  
**RHS CLUTCH CASE COVER**



**THIS KIT CONTAINS THE ITEMS PICTURED AND LABELLED OVER PAGE.**  
SOME PARTS MAY BE SHOWN FOR CLARITY OF INSTRUCTIONS ONLY.

DO NOT PROCEED UNTIL YOU ARE SURE ALL PARTS ARE PRESENT.

**PLEASE READ ALL INSTRUCTIONS BEFORE PROCEEDING.**

**IF IN ANY DOUBT WHEN FITTING OUR PRODUCTS, CONSULT ONE OF OUR DEALERS  
OR HAVE FITTED BY A QUALIFIED TECHNICIAN.**

**PLEASE BE AWARE THAT THE PLASTIC SKIDDER IS ASSEMBLED IN POSITION FOR PACKAGING  
PURPOSES ONLY. YOU WILL NEED TO REMOVE IT, PLACE 1 DROP OF BLUE THREAD LOCK TO  
EACH BOLT AND REASSEMBLE ONTO THE ALUMINIUM ENGINE CASE COVER. DO NOT EXCEED  
15NM OF TORQUE.**



<b><u>TOOLS REQUIRED</u></b>	<b><u>GENERAL TORQUE SETTINGS</u></b>
<ul style="list-style-type: none"> <li>• Set of Metric Allen keys.</li> <li>• Metric Socket set.</li> <li>• Suitable Torque Wrench.</li> </ul>	<p>M4 BOLT = 8Nm</p> <p>M5 BOLT = 12Nm</p> <p>M6 BOLT = 15Nm</p> <p>M8 BOLT = 20Nm</p> <p>M10 BOLT = 40Nm</p> <p>M12 BOLT = 40Nm</p>

**LEGEND**

<b>ITEM NO.</b>	<b>DESCRIPTION</b>	<b>QTY</b>
ITEM 1	R&G ALUMINIUM ENGINE CASE COVER	1
ITEM 2	WASHER	3
ITEM 3	M6x35mm CAP HEAD BOLT	2
ITEM 4	M6x65mm CAP HEAD BOLT	1

**ASSEMBLY DIAGRAM**





### **FITTING INSTRUCTIONS**

1. Please make sure the engine is cold before proceeding with the fitting of the R&G cover.
2. Remove the 3X OEM engine case bolts as highlighted in **PICTURE 1. DO NOT REMOVE ALL OF THE CASE BOLTS.**
3. Use the supplied 3 x cap head bolts (**ITEM 3 & 4**) and washers (**ITEM 2**) provided to secure the engine case cover to the bike using the **ASSEMBLY DIAGRAM** for reference.  
*The longer 65mm bolt should be on the mounting point with the longer standoff*
4. With a 5mm hex tool, tighten the bolts equally so that they pull the cover into place. **DO NOT FULLY TIGHTEN.**
5. Finally use a torque wrench set at 10 N/m (7 Lb/ft) to fully tighten.
6. It is suggested that you check the tightness of the mounting bolts on a regular basis such as when cleaning or once a month.
7. R&G will accept no liability if the above procedure and torque settings are not followed.
8. Store the 3X OEM engine case bolts.

ISSUE 2 - 14/05/2024 (MH)

#### **CONSUMER NOTICE**

The catalogue description and any exhibition of samples are only broad indications of the Products and R&G may make design changes which do not diminish their performance or visual appeal and supplying them in such state shall conform to the order. The Buyer acknowledges no representation or warranty (other than as to title) has been given or will apply to the Products other than those in R&G's order or confirmation and the Buyer confirms it has chosen the Products as being of merchantable quality and suitable for its particular purposes. Where R&G fits the Products or undertakes other services it shall exercise reasonable skill and care and rectify any fault free of charge unless the workmanship has been disturbed. The Buyer is responsible for ensuring that the warranty on the motorcycle is not affected by the fitting of the Products. On return of any defective Products R&G shall at its option either supply a replacement or refund the purchase money but shall not be liable if the Products have been modified or used or maintained otherwise than in accordance with R&G's or manufacturer's instructions and good engineering practice or if the defect arises from accident or neglect. Other than identified above and subject to R&G not limiting its liability for causing death and personal injury, it shall not be liable for indirect or consequential loss and otherwise its liability shall be limited to the amounts paid by the Buyer for the Products or the fitting or service concerned. These terms do not affect the Buyer's statutory rights.

#### **R&G RETURNS POLICY (NON-FAULTY GOODS)**

Returns must be pre-authorized (if not pre-authorized the return will be rejected). Goods may only be returned direct to us if they were purchased direct from us (customer must prove if necessary). Otherwise to be returned to original vendor. Goods must be in re-sellable condition, in the opinion of R&G. All returns are subject to a 25% restocking and handling fee (25% of the gross value exc. P&P - at the prevailing price at time of purchase). The customer must pay any and all carriage charges. No returns of discontinued products, unless within 14 days of purchase. This policy does not affect your statutory rights and does not refer to faulty goods.

R&G

Unit 1, Shelley's Lane, East Worldham, Alton, Hampshire, GU34 3AQ

Tel: +44 (0)1420 89007 Fax: +44 (0)1420 87301 [www.rg-racing.com](http://www.rg-racing.com) Email: [info@rg-racing.com](mailto:info@rg-racing.com)



**FITTING INSTRUCTIONS FOR ECC0402PRO**  
**RHS OIL PUMP COVER**



**THIS KIT CONTAINS THE ITEMS PICTURED AND LABELLED OVER PAGE.**  
SOME PARTS MAY BE SHOWN FOR CLARITY OF INSTRUCTIONS ONLY.

DO NOT PROCEED UNTIL YOU ARE SURE ALL PARTS ARE PRESENT.

**PLEASE READ ALL INSTRUCTIONS BEFORE PROCEEDING.**

**IF IN ANY DOUBT WHEN FITTING OUR PRODUCTS, CONSULT ONE OF OUR DEALERS  
OR HAVE FITTED BY A QUALIFIED TECHNICIAN.**

**PLEASE BE AWARE THAT THE PLASTIC SKIDDER IS ASSEMBLED IN POSITION FOR PACKAGING  
PURPOSES ONLY. YOU WILL NEED TO REMOVE IT, PLACE 1 DROP OF BLUE THREAD LOCK TO  
EACH BOLT AND REASSEMBLE ONTO THE ALUMINIUM ENGINE CASE COVER. DO NOT EXCEED  
15NM OF TORQUE.**



<b><u>TOOLS REQUIRED</u></b>	<b><u>GENERAL TORQUE SETTINGS</u></b>
<ul style="list-style-type: none"> <li>• Set of Metric Allen keys.</li> <li>• Metric Socket set.</li> <li>• Suitable Torque Wrench.</li> </ul>	M4 BOLT = 8Nm M5 BOLT = 12Nm M6 BOLT = 15Nm M8 BOLT = 20Nm M10 BOLT = 40Nm M12 BOLT = 40Nm

### **LEGEND**

<b>ITEM NO.</b>	<b>DESCRIPTION</b>	<b>QTY</b>
ITEM 1	R&G ALUMINIUM ENGINE CASE COVER	1
ITEM 2	WASHER	4
ITEM 3	M6x35mm CAP HEAD BOLT	4

### **ASSEMBLY DIAGRAM**





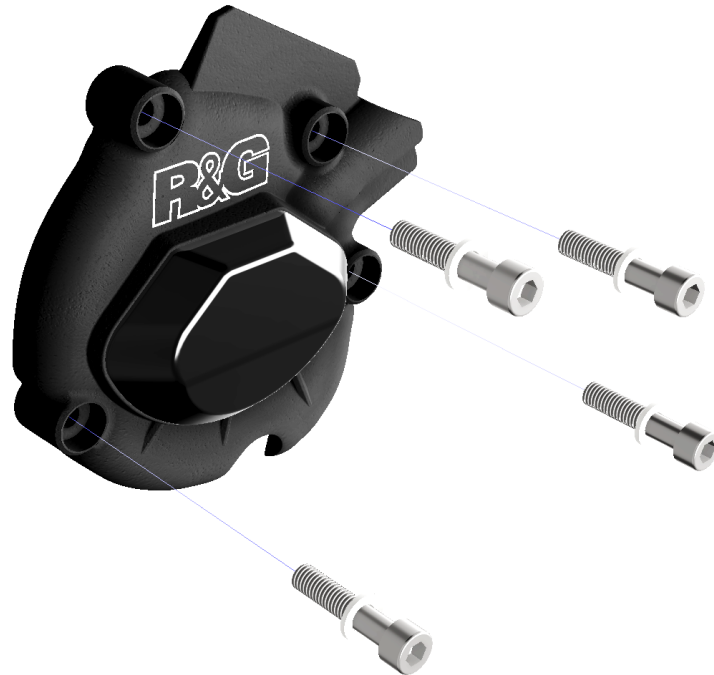

### **FITTING INSTRUCTIONS**

9. Please make sure the engine is cold before proceeding with the fitting of the R&G cover.
10. Make sure the countersunk bolts on the inside of the case cover are tight.
11. Remove the 4X OEM engine case bolts as highlighted in **PICTURE 1. DO NOT REMOVE ALL OF THE CASE BOLTS.**
12. Use the supplied 4X cap head bolts (**ITEM 3**) and washers (**ITEM 2**) provided to secure the engine case cover to the bike using the **ASSEMBLY DIAGRAM** for reference.
13. With a 5mm hex tool, tighten the bolts equally so that they pull the cover into place. **DO NOT FULLY TIGHTEN.**
14. Finally use a torque wrench set at 10 N/m (7 Lb/ft) to fully tighten.
15. It is suggested that you check the tightness of the mounting bolts on a regular basis such as when cleaning or once a month.
16. R&G will accept no liability if the above procedure and torque settings are not followed.
17. Store the 4X OEM engine case bolts.

ISSUE 2 – 14/05/2024 (MH)

#### **CONSUMER NOTICE**

The catalogue description and any exhibition of samples are only broad indications of the Products and R&G may make design changes which do not diminish their performance or visual appeal and supplying them in such state shall conform to the order. The Buyer acknowledges no representation or warranty (other than as to title) has been given or will apply to the Products other than those in R&G's order or confirmation and the Buyer confirms it has chosen the Products as being of merchantable quality and suitable for its particular purposes. Where R&G fits the Products or undertakes other services it shall exercise reasonable skill and care and rectify any fault free of charge unless the workmanship has been disturbed. The Buyer is responsible for ensuring that the warranty on the motorcycle is not affected by the fitting of the Products. On return of any defective Products R&G shall at its option either supply a replacement or refund the purchase money but shall not be liable if the Products have been modified or used or maintained otherwise than in accordance with R&G's or manufacturer's instructions and good engineering practice or if the defect arises from accident or neglect. Other than identified above and subject to R&G not limiting its liability for causing death and personal injury, it shall not be liable for indirect or consequential loss and otherwise its liability shall be limited to the amounts paid by the Buyer for the Products or the fitting or service concerned. These terms do not affect the Buyer's statutory rights.

R&G

Unit 1, Shelley's Lane, East Worldham, Alton, Hampshire, GU34 3AQ

Tel: +44 (0)1420 89007 Fax: +44 (0)1420 87301 [www.rg-racing.com](http://www.rg-racing.com) Email: [info@rg-racing.com](mailto:info@rg-racing.com)

**R&G RETURNS POLICY (NON-FAULTY GOODS)**

Returns must be pre-authorized (if not pre-authorized the return will be rejected). Goods may only be returned direct to us if they were purchased direct from us (customer must prove if necessary). Otherwise to be returned to original vendor. Goods must be in re-sellable condition, in the opinion of R&G. All returns are subject to a 25% restocking and handling fee (25% of the gross value exc. P&P – at the prevailing price at time of purchase). The customer must pay any and all carriage charges. No returns of discontinued products, unless within 14 days of purchase. This policy does not affect your statutory rights and does not refer to faulty goods.

R&amp;G

Unit 1, Shelley's Lane, East Worldham, Alton, Hampshire, GU34 3AQ

Tel: +44 (0)1420 89007 Fax: +44 (0)1420 87301 [www.rg-racing.com](http://www.rg-racing.com) Email: [info@rg-racing.com](mailto:info@rg-racing.com)