



**FITTING INSTRUCTIONS FOR CP0581 CRASH PROTECTORS**



**THIS KIT CONTAINS THE ITEMS PICTURED AND LABELLED OVER PAGE.**

SOME PARTS MAY BE SHOWN FOR CLARITY OF INSTRUCTIONS ONLY.

DO NOT PROCEED UNTIL YOU ARE SURE ALL PARTS ARE PRESENT.

**PLEASE READ ALL INSTRUCTIONS BEFORE PROCEEDING.**

**IF IN ANY DOUBT WHEN FITTING OUR PRODUCTS, CONSULT ONE OF OUR DEALERS  
OR HAVE FITTED BY A QUALIFIED TECHNICIAN.**

PLEASE NOTE THAT THE WAY THE KIT IS PACKED DOES NOT NECESSARILY REPRESENT THE WAY OF  
MOUNTING TO THE BIKE.

IN THE EVENT OF RUBBER WASHERS BEING USED TO HOLD COMPONENTS ONTO BOLTS,  
THESE RUBBER WASHERS CAN BE THROWN AWAY.

**DIGITAL COPIES OF THESE INSTRUCTIONS ARE AVAILABLE FROM:**

[WWW.RG-RACING.COM](http://WWW.RG-RACING.COM)

R&G  
Unit 1, Shelley's Lane, East Worldham, Alton, Hampshire, GU34 3AQ  
Tel: +44 (0)1420 89007 [www.rg-racing.com](http://www.rg-racing.com) Email: [info@rg-racing.com](mailto:info@rg-racing.com)

**GENERAL TORQUE SETTINGS**

M4 BOLT = 8Nm  
 M5 BOLT = 12Nm  
 M6 BOLT = 15Nm  
 M8 BOLT = 20Nm  
 M10 BOLT = 40Nm

**TOOLS REQUIRED**

- Torque Wrench
- Scissor Jack
- 14, 17mm & 19mm Sockets and Ratchet

**LEGEND**

ITEM NO.	DESCRIPTION	QTY
ITEM 1	B0061 M10 CRASH PROTECTOR	2
ITEM 2	BC0002 - CRASH PROTECTOR CAP	2
ITEM 3	M10X1.50X110 - HEX ENGINE BOLT - LHS	1
ITEM 4	M10X1.50X130 HEX - HEX ENGINE BOLT - RHS	1
ITEM 5	S1556 - 32MM SPACER LHS	1
ITEM 6	S1557 - 37MM SPACER RHS	1
ITEM 7	S0293 RHS - 5MM	1
ITEM 8	M10X20 O/D - WASHER	2
ITEM 9	LW0001 - LOCKING WASHER	2

**AERO STYLE CRASH-PROTECTOR ORIENTATION**

R&amp;G

Unit 1, Shelley's Lane, East Worldham, Alton, Hampshire, GU34 3AQ  
 Tel: +44 (0)1420 89007 [www.rg-racing.com](http://www.rg-racing.com) Email: [info@rg-racing.com](mailto:info@rg-racing.com)



**LHS ASSEMBLY**

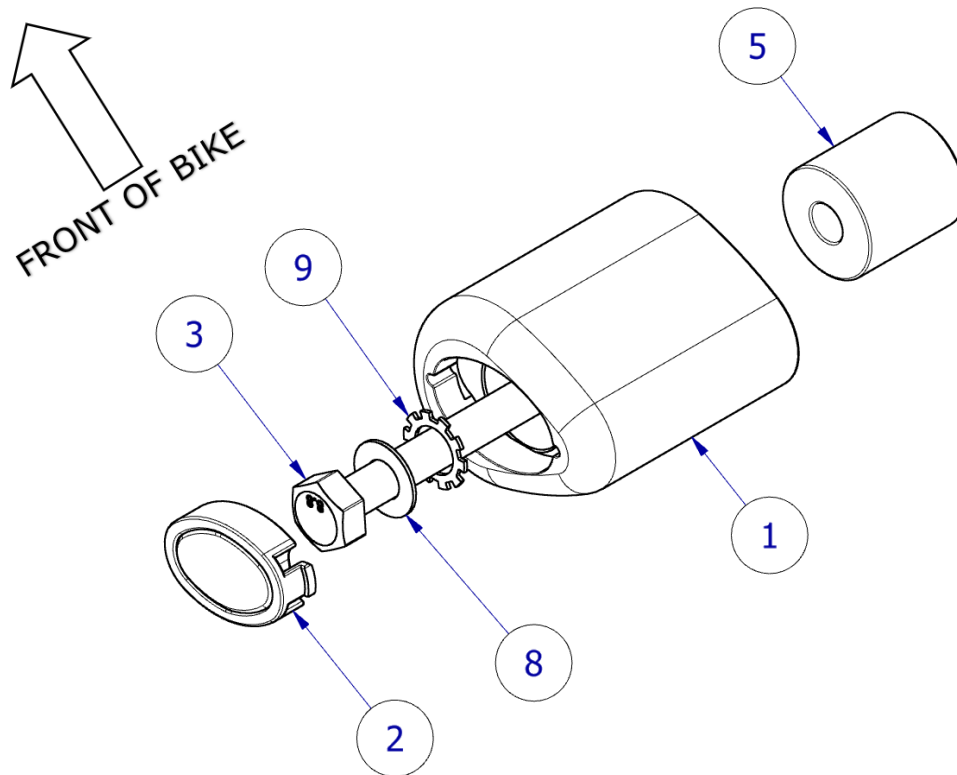

**RHS ASSEMBLY**

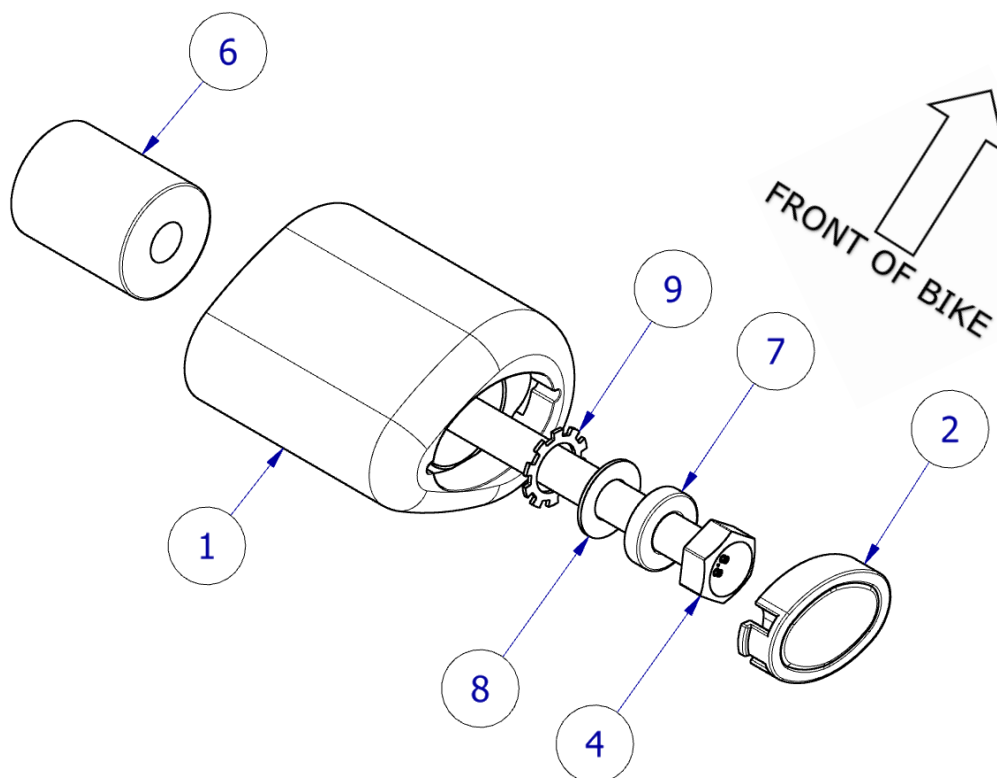



## FITTING IMAGES



**PICTURE 1**



**PICTURE 2**

## FITTING INSTRUCTIONS

**IMPORTANT: Before removing engine bolts, ensure the bike is upright and supported by a suitable engine stand or jack placed under the sump of the motorbike to support the partial weight of the engine, this will prevent the engine from moving during fitting. DO NOT REMOVE MORE THAN ONE ENGINE BOLT AT ANY TIME.**

### Left-Hand Side

- Remove the LHS engine bolt shown in **picture 1**. Also remove the OEM 4mm spacer under the bolt head as this will not be needed for reassembly.
- Assemble the LHS crash protector assembly according to the assembly diagram on page 3. Ensure to use the correct spacer (Item 5) for the LHS.
- Fix the crash protector into the exposed engine mount and torque to the recommended specification. **PLEASE NOTE, THE CRASH PROTECTOR MUST BE POSITIONED AS IN THE DIAGRAM ON PAGE 2, WITH THE LARGER END TOWARDS THE FRONT OF THE BIKE.**

### Right-Hand Side

- Moving to the RHS of the motorcycle, remove the engine bolt arrowed in **picture 2**. Also remove the OEM 4mm spacer under the bolt head as this will not be needed for reassembly.
- Assemble the RHS crash protector according to the assembly diagram on page 3. Ensure to place the 5mm spacer (item 7) under the bolt head as this is essential for the correct thread engagement when fitting.

R&G

Unit 1, Shelley's Lane, East Worldham, Alton, Hampshire, GU34 3AQ  
Tel: +44 (0)1420 89007 Fax: [www.rg-racing.com](http://www.rg-racing.com) Email: [info@rg-racing.com](mailto:info@rg-racing.com)



- Fix the crash protector into the frame and engine and tighten to the recommended torque. **PLEASE NOTE, THE CRASH PROTECTOR MUST BE POSITIONED AS IN THE DIAGRAM ON PAGE 2, WITH THE LARGER END TOWARDS THE FRONT OF THE BIKE.**

### **Both-Sides**

- Finally, fit the bobbin caps (item 2) to both crash protectors, as shown in **picture 5**.
- Before riding, check both sides are secure, and the crash protectors cannot rotate.
- Check tightness of each side regularly.

ISSUE 1 – 23/09/2024 – DM

### **CONSUMER NOTICE**

The catalogue description and any exhibition of samples are only broad indications of the Products and R&G may make design changes which do not diminish their performance or visual appeal and supplying them in such state shall conform to the order. The Buyer acknowledges no representation or warranty (other than as to title) has been given or will apply to the Products other than those in R&G's order or confirmation and the Buyer confirms it has chosen the Products as being of merchantable quality and suitable for its particular purposes. Where R&G fits the Products or undertakes other services it shall exercise reasonable skill and care and rectify any fault free of charge unless the workmanship has been disturbed. The Buyer is responsible for ensuring that the warranty on the motorcycle is not affected by the fitting of the Products. On return of any defective Products R&G shall at its option either supply a replacement or refund the purchase money but shall not be liable if the Products have been modified or used or maintained otherwise than in accordance with R&G's or manufacturer's instructions and good engineering practice or if the defect arises from accident or neglect. Other than identified above and subject to R&G not limiting its liability for causing death and personal injury, it shall not be liable for indirect or consequential loss and otherwise its liability shall be limited to the amounts paid by the Buyer for the Products or the fitting or service concerned. These terms do not affect the Buyer's statutory rights.

### **R&G RACING RETURNS POLICY (NON-FAULTY GOODS)**

Returns must be pre-authorized (if not pre-authorized the return will be rejected). Goods may only be returned direct to us if they were purchased direct from us (customer must prove if necessary). Otherwise to be returned to original vendor. Goods must be in re-sellable condition, in the opinion of R&G Racing. All returns are subject to a 25% restocking and handling fee (25% of the gross value exc. P&P – at the prevailing price at time of purchase). The customer must pay any and all carriage charges. No returns of discontinued products, unless within 14 days of purchase. This policy does not affect your statutory rights and does not refer to faulty goods.

R&G

Unit 1, Shelley's Lane, East Worldham, Alton, Hampshire, GU34 3AQ  
Tel: +44 (0)1420 89007 Fax: [www.rg-racing.com](http://www.rg-racing.com) Email: [info@rg-racing.com](mailto:info@rg-racing.com)