

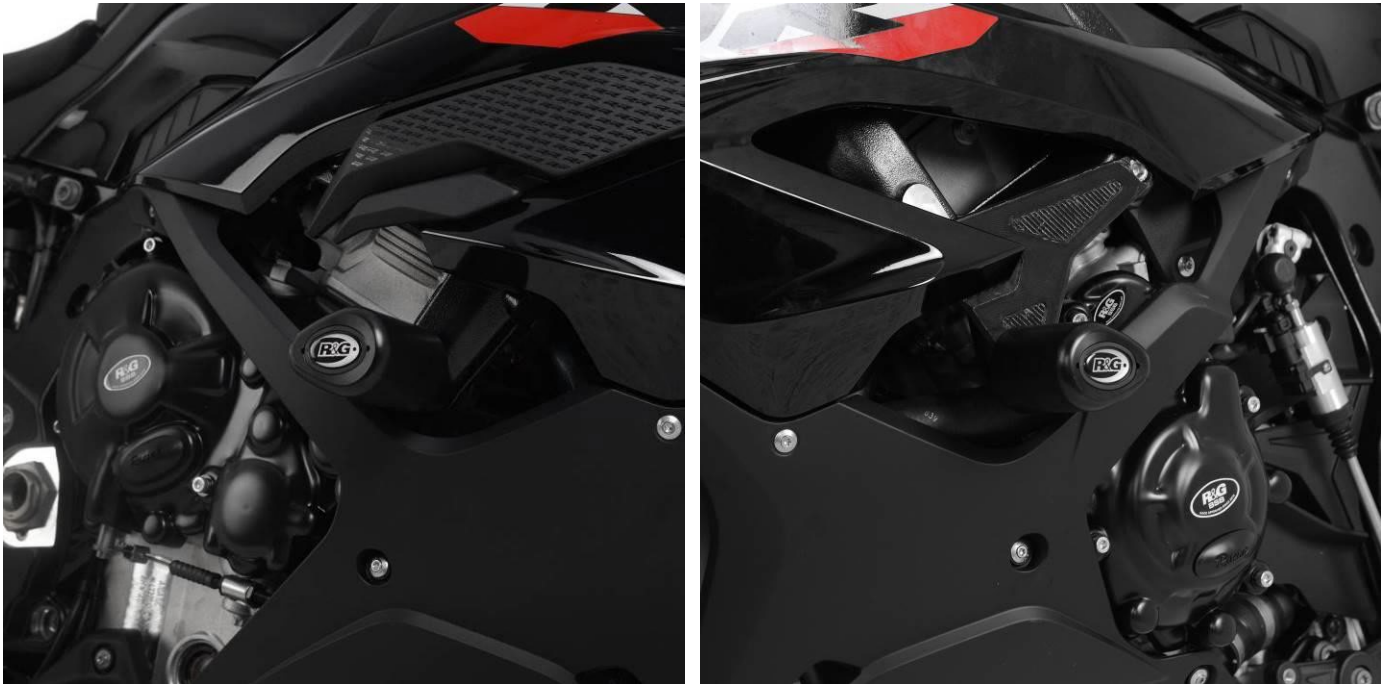

FITTING INSTRUCTIONS FOR CP0551 SYMMETRICAL CRASH PROTECTORS



THIS KIT CONTAINS THE ITEMS PICTURED AND LABELLED OVER PAGE.

SOME PARTS MAY BE SHOWN FOR CLARITY OF INSTRUCTIONS ONLY.

DO NOT PROCEED UNTIL YOU ARE SURE ALL PARTS ARE PRESENT.

PLEASE READ ALL INSTRUCTIONS BEFORE PROCEEDING.

**IF IN ANY DOUBT WHEN FITTING OUR PRODUCTS, CONSULT ONE OF OUR DEALERS
OR HAVE FITTED BY A QUALIFIED TECHNICIAN.**

PLEASE NOTE THAT THE WAY THE KIT IS PACKED DOES NOT NECESSARILY REPRESENT THE WAY OF
MOUNTING TO THE BIKE.

IN THE EVENT OF RUBBER WASHERS BEING USED TO HOLD COMPONENTS ONTO BOLTS,
THESE RUBBER WASHERS CAN BE THROWN AWAY.

DIGITAL COPIES OF THESE INSTRUCTIONS ARE AVAILABLE FROM:

WWW.RG-RACING.COM

R&G

Unit 1, Shelley's Lane, East Worldham, Alton, Hampshire, GU34 3AQ

Tel: +44 (0)1420 89007 Fax: +44 (0)1420 87301 www.rg-racing.com Email: info@rg-racing.com



<u>GENERAL TORQUE SETTINGS</u>	<u>TOOLS REQUIRED</u>
M4 BOLT = 8Nm M5 BOLT = 12Nm M6 BOLT = 15Nm M8 BOLT = 20Nm M10 BOLT = 40Nm	<ul style="list-style-type: none"> • T50 Torx Key/Socket • Torque Wrench • Scissor Jack • 17mm Socket and Ratchet

LEGEND

ITEM NO.	DESCRIPTION	QTY
ITEM 1	M0750 – CRASH PROTECTOR FIXING BRACKET	1
ITEM 2	B0061 - CRASH PROTECTOR	2
ITEM 3	M10x1.50x75mm COUNTERSUNK BOLT	2
ITEM 4	M10x1.25x60 HEX HEAD BOLT	1
ITEM 5	M10x1.50x110mm HEX HEAD BOLT	1
ITEM 6	S0142 – SPACER	1
ITEM 7	LW0001 – ANTI-ROTATION WASHER	2
ITEM 8	M10x19 PLAIN WASHER	2
ITEM 9	BC0002 – BOBBIN CAP	2
ITEM 10	FS0002 - SELF ADHESIVE FOAM	2

AERO STYLE CRASH-PROTECTOR ORIENTATION



R&G

Unit 1, Shelley's Lane, East Worldham, Alton, Hampshire, GU34 3AQ

Tel: +44 (0)1420 89007 Fax: +44 (0)1420 87301 www.rg-racing.com Email: info@rg-racing.com



LHS ASSEMBLY

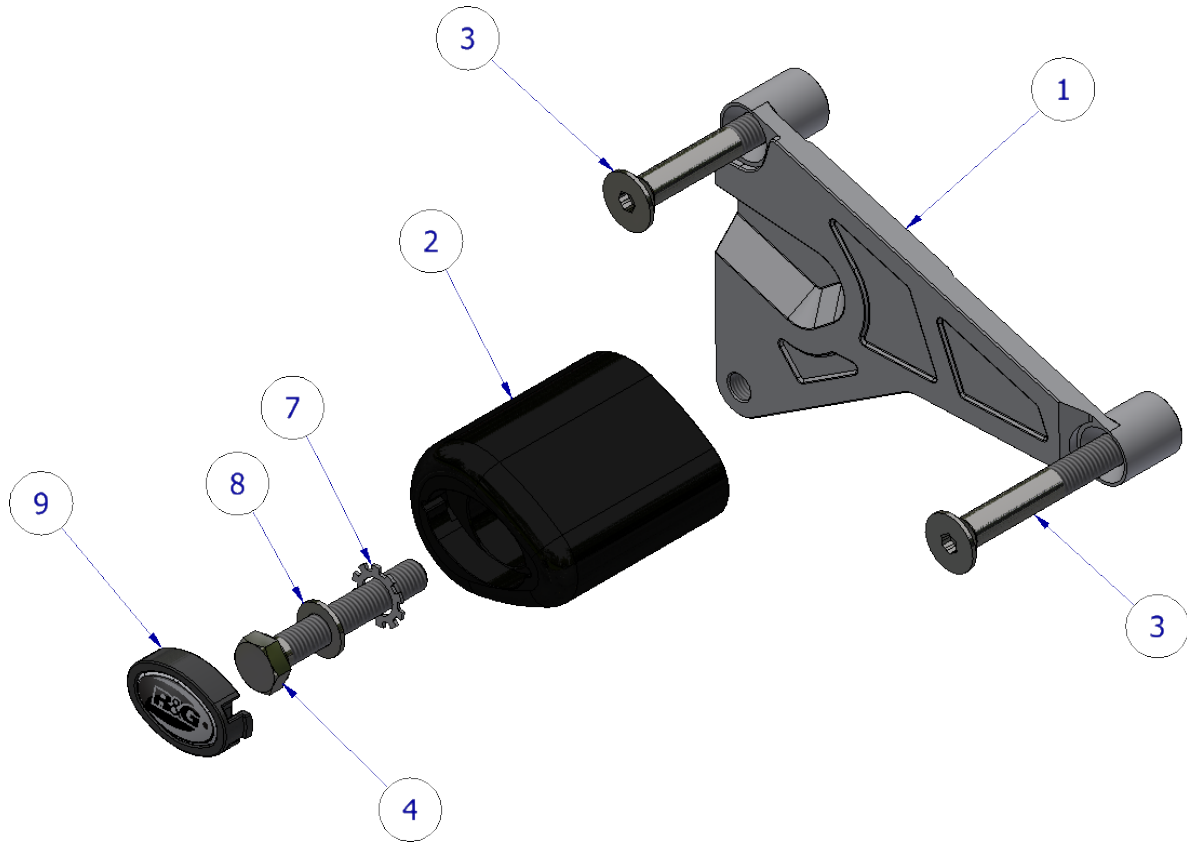

RHS ASSEMBLY

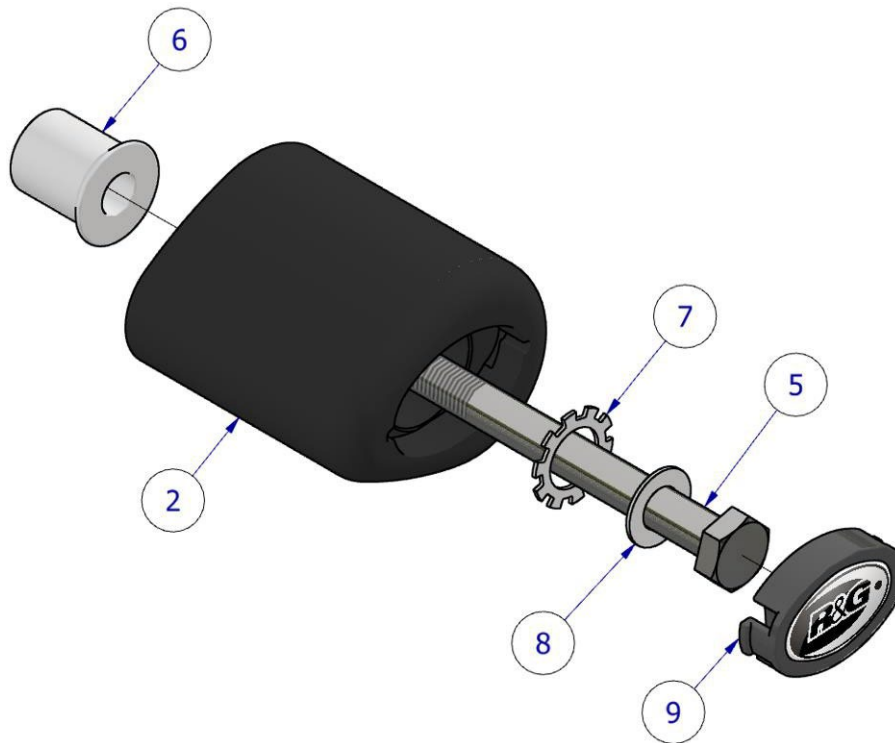

R&G

Unit 1, Shelley's Lane, East Worldham, Alton, Hampshire, GU34 3AQ

Tel: +44 (0)1420 89007 Fax: +44 (0)1420 87301 www.rg-racing.com Email: info@rg-racing.com

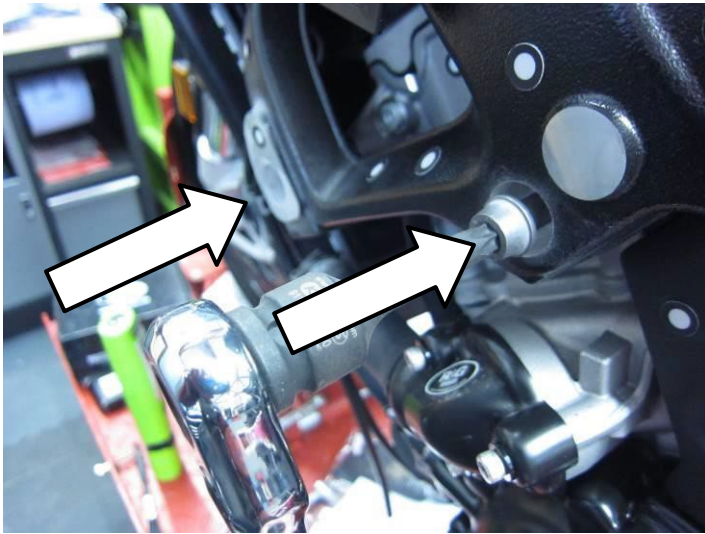

PICTURE 1



PICTURE 2

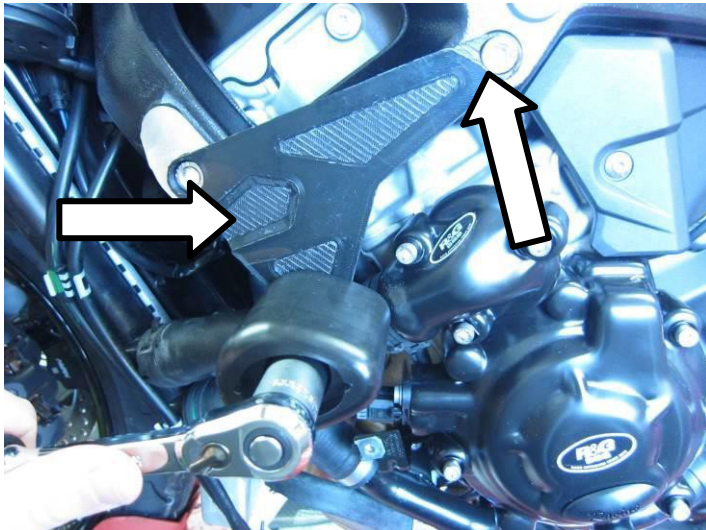

PICTURE 3

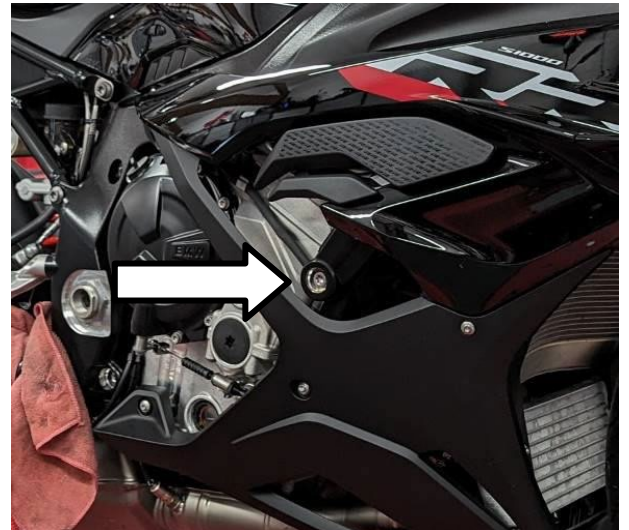

PICTURE 4



PICTURE 5



PICTURE 6



FITTING INSTRUCTIONS

Before removing engine bolts, ensure the bike is upright and supported by a suitable engine stand or jack placed under the sump of the motorbike to support the partial weight of the engine, this will prevent the engine from moving during fitting.

DO NOT REMOVE ENGINE BOLTS FROM BOTH SIDES AT THE SAME TIME.

Left-Hand Side

- Begin by removing the LHS fairing piece according to the manufacturers service manual.
- Remove the LHS engine bolts shown in **picture 1** & **picture 2** using a T50 Torx tool.
- Referring to the assembly diagram on page 3 – fit the Metal bracket M0750 ash shown in picture 1 using the two countersunk bolts (item 3). Torque bolts to the recommended setting.
- Re-fit the fairing as removed – during this stage be careful to avoid contact between the mounting bracket and fairing during fitting.

NOTE: For M1000R Model – The inner plastic fairing will need to be trimmed using a Dremel or similar tool in the area shown in **Picture 6**, this will not be visible once fairing has been re-fitted.

- Because of variation in fairings and wind-flex at higher speeds, it is recommended to place a piece of provided foam (item 10) in the areas highlighted in **picture 3** in case of contact.
- Assemble the LHS crash protector assembly according to the assembly diagram on page 3.
- Fix the crash protector into the mount bracket and torque to the recommended specification.

PLEASE NOTE, THE CRASH PROTECTOR MUST BE POSITIONED AS IN THE DIAGRAM ON PAGE 2, WITH THE LARGER END TOWARDS THE FRONT OF THE BIKE.

Right-Hand Side

- Moving to the RHS of the motorcycle, remove the engine bolt arrowed in **picture 4** using a T50 Torx tool.
- Referring to the RHS assembly diagram on page 3 and shown in picture 3. First slide a washer (item 8) over the longest included hex-head bolt (item 5), followed by one of the serrated washers (item 7). Next, slide the bolt assembly through one of the included crash protectors (item 2), then slide the spacer (item 6) over the exposed end of the bolt, ensuring the tapered end sits against the rear face of the crash protector.
- Fix the crash protector into the frame and engine and tighten to the recommended torque. **PLEASE NOTE, THE CRASH PROTECTOR MUST BE POSITIONED AS IN THE DIAGRAM ON PAGE 2, WITH THE LARGER END TOWARDS THE FRONT OF THE BIKE.**

Both-Sides

- Finally, fit the bobbin caps (item 4) to both crash protectors, as shown in **picture 5**.
- Before riding, check both sides are secure, and the crash protectors cannot rotate.
- Check tightness of each side regularly.

See more R&G products for your Motorcycle On:

RG-RACING.COM

ISSUE 3 – 13/08/2024 – MH

R&G

Unit 1, Shelley's Lane, East Worldham, Alton, Hampshire, GU34 3AQ

Tel: +44 (0)1420 89007 Fax: +44 (0)1420 87301 www.rg-racing.com Email: info@rg-racing.com



CONSUMER NOTICE

The catalogue description and any exhibition of samples are only broad indications of the Products and R&G may make design changes which do not diminish their performance or visual appeal and supplying them in such state shall conform to the order. The Buyer acknowledges no representation or warranty (other than as to title) has been given or will apply to the Products other than those in R&G's order or confirmation and the Buyer confirms it has chosen the Products as being of merchantable quality and suitable for its particular purposes. Where R&G fits the Products or undertakes other services it shall exercise reasonable skill and care and rectify any fault free of charge unless the workmanship has been disturbed. The Buyer is responsible for ensuring that the warranty on the motorcycle is not affected by the fitting of the Products. On return of any defective Products R&G shall at its option either supply a replacement or refund the purchase money but shall not be liable if the Products have been modified or used or maintained otherwise than in accordance with R&G's or manufacturer's instructions and good engineering practice or if the defect arises from accident or neglect. Other than identified above and subject to R&G not limiting its liability for causing death and personal injury, it shall not be liable for indirect or consequential loss and otherwise its liability shall be limited to the amounts paid by the Buyer for the Products or the fitting or service concerned. These terms do not affect the Buyer's statutory rights.

R&G RACING RETURNS POLICY (NON-FAULTY GOODS)

Returns must be pre-authorized (if not pre-authorized the return will be rejected). Goods may only be returned direct to us if they were purchased direct from us (customer must prove if necessary). Otherwise to be returned to original vendor. Goods must be in re-sellable condition, in the opinion of R&G Racing. All returns are subject to a 25% restocking and handling fee (25% of the gross value exc. P&P – at the prevailing price at time of purchase). The customer must pay any and all carriage charges. No returns of discontinued products, unless within 14 days of purchase. This policy does not affect your statutory rights and does not refer to faulty goods.

NOTICE DE MONTAGE CP0551 PROTECTIONS CRASH

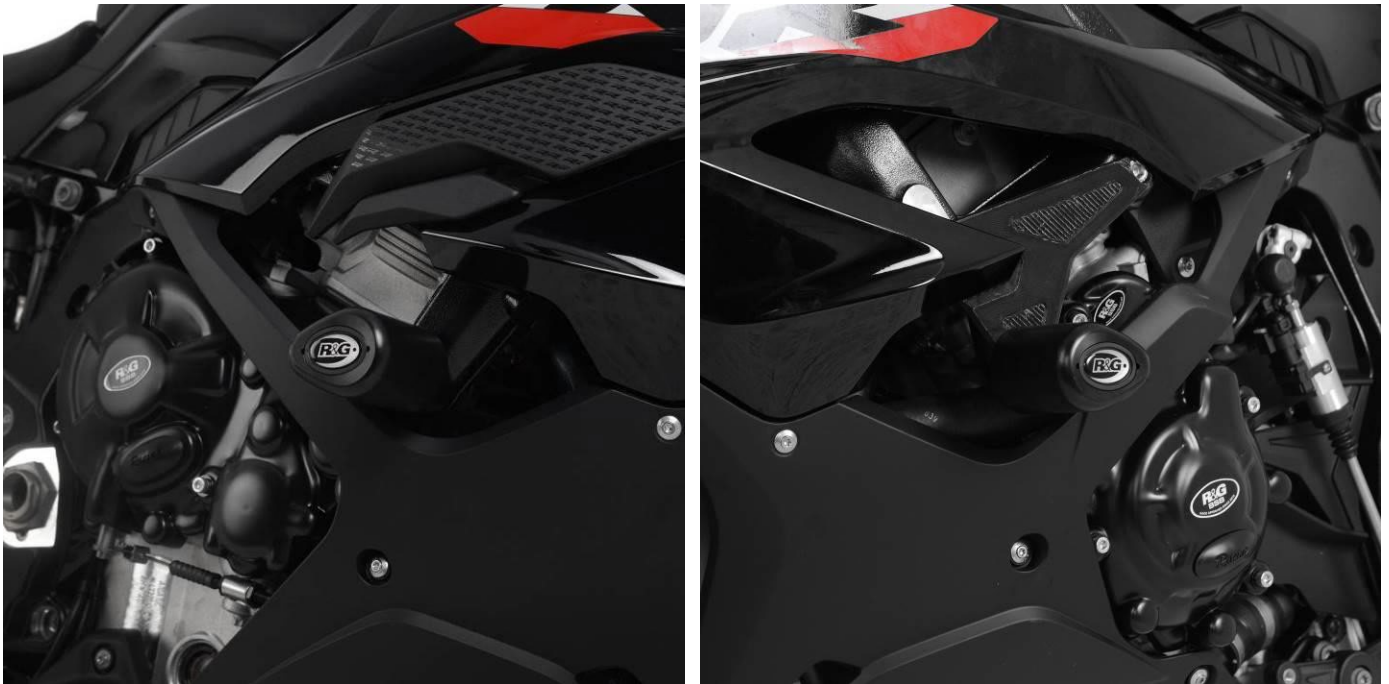

CE KIT CONTIENT LES ARTICLES ILLUSTRÉS ET ÉTIQUETES SUR LA PAGE.

CERTAINES PARTIES PEUVENT ÊTRE PRÉSENTES UNIQUEMENT POUR LA CLARTÉ DES INSTRUCTIONS.

NE PAS PROCÉDER AU MONTAGE TANT QUE VOUS N'ÊTES PAS SÛR QUE TOUTES LES PIÈCES SOIENT PRÉSENTES.

VEUILLEZ LIRE TOUTES LES INSTRUCTIONS AVANT DE CONTINUER.

R&G

Unit 1, Shelley's Lane, East Worldham, Alton, Hampshire, GU34 3AQ

Tel: +44 (0)1420 89007 Fax: +44 (0)1420 87301 www.rg-racing.com Email: info@rg-racing.com



**EN CAS DE DOUTE LORS DU MONTAGE DE NOS PRODUITS, CONSULTEZ UN DE NOS
REVENDEURS OU FAITES APPEL A UN TECHNICIEN QUALIFIÉ.**

VEUILLEZ NOTER QUE LA FAÇON DONT LE KIT EST EMBALLE NE REPRESENTE PAS NECESSAIREMENT LA MANIERE DE LE
MONTER SUR LA MOTO.

SI DES RONDELLES EN CAOUTCHOUC SONT UTILISEES POUR MAINTENIR LES COMPOSANTS SUR LES BOULONS, ELLES
PEUVENT ETRE JETEES.

NOTICE DISPONIBLE AU TELECHARGEMENT SUR :

WWW.RG-RACING.COM

R&G

Unit 1, Shelley's Lane, East Worldham, Alton, Hampshire, GU34 3AQ

Tel: +44 (0)1420 89007 Fax: +44 (0)1420 87301 www.rg-racing.com Email: info@rg-racing.com



<u>VALEURS DE SERRAGE</u>	<u>OUTILS REQUIS</u>
M4 BOULON = 8Nm	<ul style="list-style-type: none"> • Clé Torx T50 • Clé dynamométrique • Cric à ciseaux • Clé à cliquet + douille 17mm
M5 BOULON = 12Nm	
M6 BOULON = 15Nm	
M8 BOULON = 20Nm	
M10 BOULON = 40Nm	

LÉGENDE

ARTICLE NO.	DESCRIPTION	QTÉ
ARTICLE 1	M0750 – SUPPORT DE FIXATION DE PROTECTION CRASH	1
ARTICLE 2	B0061 - PROTECTION CRASH	2
ARTICLE 3	M10x1.50x75mm BOULON	2
ARTICLE 4	M10x1.25x60 BOULON	1
ARTICLE 5	M10x1.50x110mm BOULON	1
ARTICLE 6	S0142 – ENTRETOISE	1
ARTICLE 7	LW0001 – RONDELLE ANTI-ROTATION	2
ARTICLE 8	M10x19 RONDELLE	2
ARTICLE 9	BC0002 – CAPUCHON DE PROTECTION	2
ARTICLE 10	FS0002 – BANDEAU DE MOUSSE AUTOCOLLANT	2

ORIENTATION DE LA PROTECTION CRASH



R&G

Unit 1, Shelley's Lane, East Worldham, Alton, Hampshire, GU34 3AQ

Tel: +44 (0)1420 89007 Fax: +44 (0)1420 87301 www.rg-racing.com Email: info@rg-racing.com



ASSEMBLAGE CÔTÉ GAUCHE

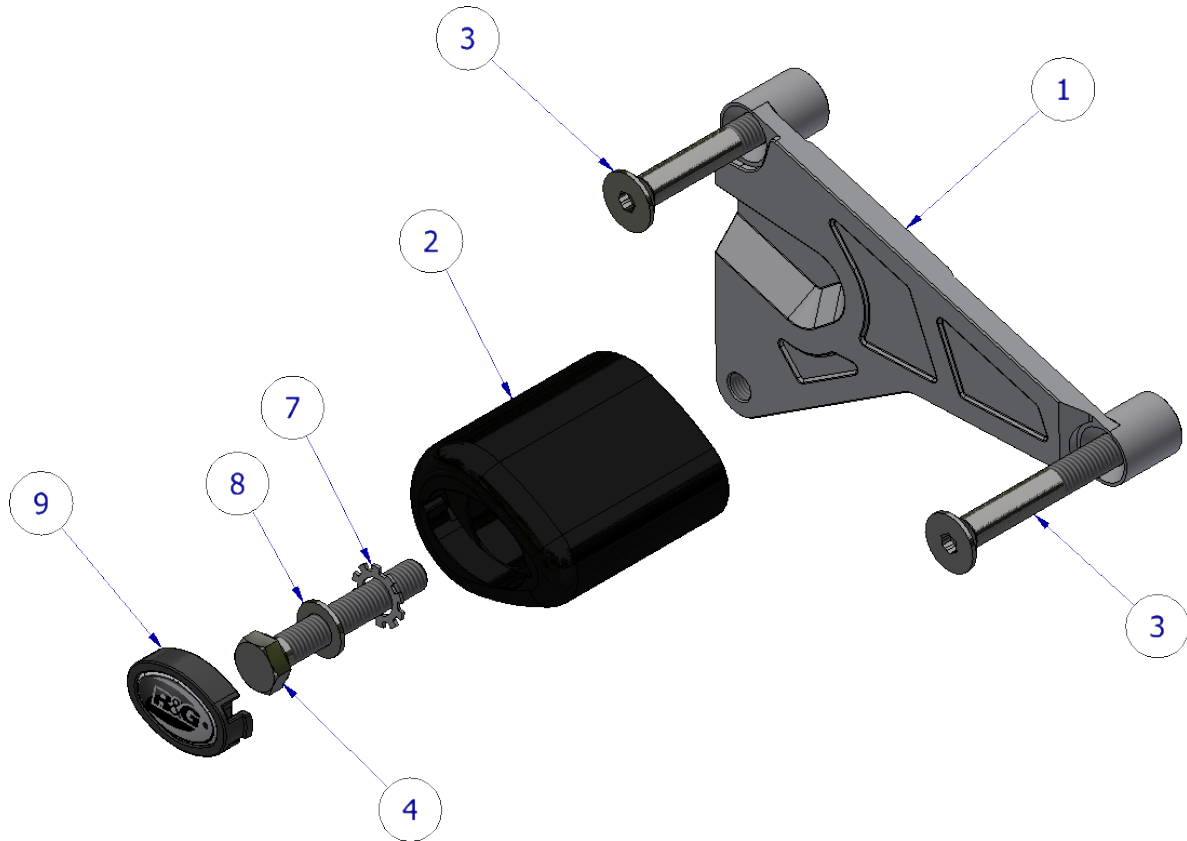

ASSEMBLAGE CÔTÉ DROIT

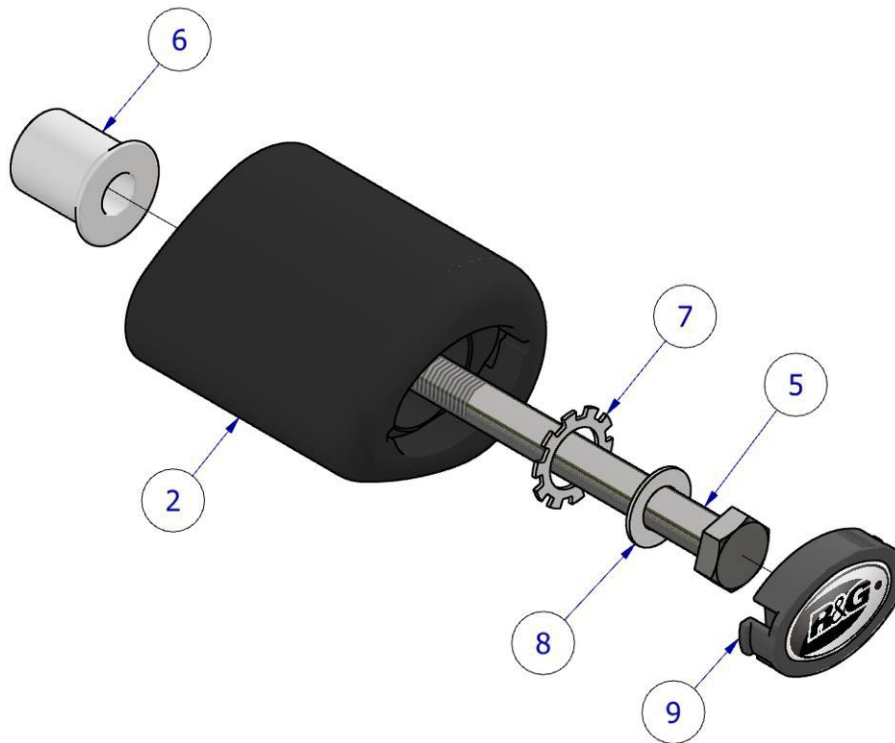

R&G

Unit 1, Shelley's Lane, East Worldham, Alton, Hampshire, GU34 3AQ

Tel: +44 (0)1420 89007 Fax: +44 (0)1420 87301 www.rg-racing.com Email: info@rg-racing.com

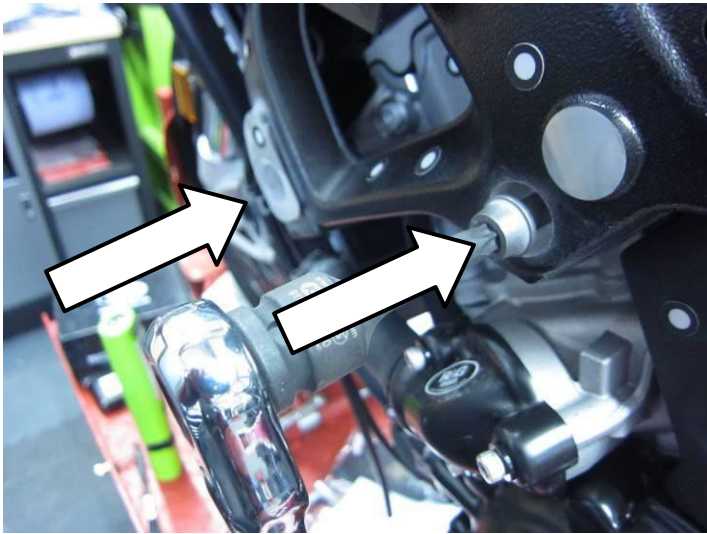

PHOTO 1



PHOTO 2

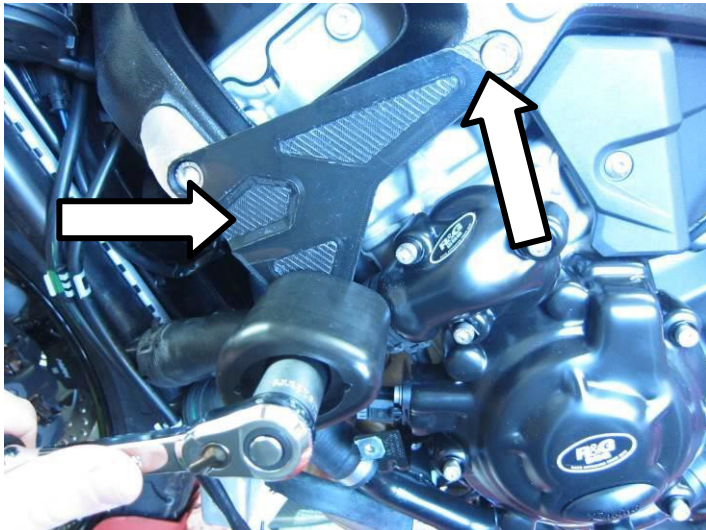

PHOTO 3

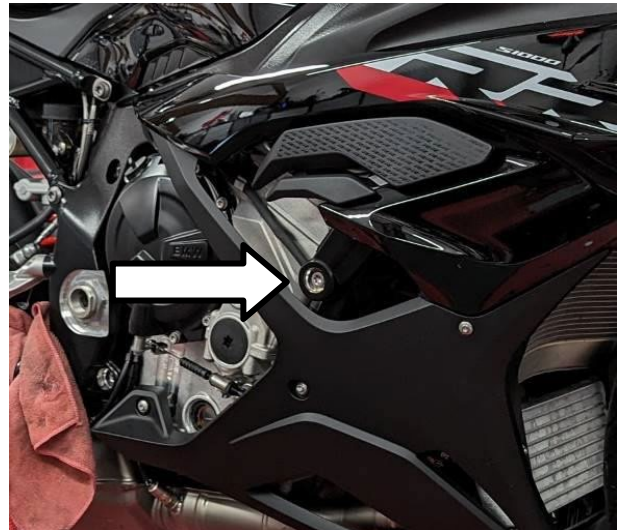

PHOTO 4



PHOTO 5



PHOTO 6

R&G

Unit 1, Shelley's Lane, East Worldham, Alton, Hampshire, GU34 3AQ

Tel: +44 (0)1420 89007 Fax: +44 (0)1420 87301 www.rg-racing.com Email: info@rg-racing.com



NOTICE DE MONTAGE

Avant de retirer les boulons du moteur, assurez-vous que la moto soit droite et soutenue par un support moteur ou un cric approprié placé sous le carter de la moto pour supporter le poids partiel du moteur, cela empêchera le moteur de bouger pendant le montage.

NE RETIREZ PAS PLUS D'UN BOULON DU MOTEUR À LA FOIS.

Côté gauche

- Commencez par retirer la pièce de carénage gauche conformément au manuel d'entretien du fabricant.
- Retirez les boulons du moteur gauche illustrés sur la photo 1 et la photo 2 à l'aide d'une clé Torx T50.
- En vous référant au schéma de montage de la page 3, installez le support métallique M0750 illustré sur la photo 1 à l'aide des deux boulons à tête fraisée (article 3). Serrez les boulons au couple recommandé.
- Remontez le carénage tel qu'il a été retiré - pendant cette étape, veillez à éviter tout contact entre le support de montage et le carénage lors du montage.

NOTE: Pour le modèle M1000R – Le carénage intérieur en plastique devra être coupé à l'aide d'un outil Dremel ou d'un outil similaire dans la zone indiquée sur la photo 6, cela ne sera pas visible une fois le carénage remonté.

- En raison des variations de carénages et de flexion au vent à des vitesses plus élevées, il est recommandé de placer un morceau de mousse fourni (article 10) dans les zones mises en évidence sur la photo 3 en cas de contact.
- Assemblez l'ensemble de protection crash côté gauche selon le schéma d'assemblage de la page 3.
- Fixez la protection crash dans le support de montage et serrez au couple recommandé.

ATTENTION, LA PROTECTION CRASH DOIT ÊTRE POSITIONNÉE COMME SUR LE SCHÉMA DE LA PAGE 2, AVEC L'EXTRÉMITÉ LA PLUS GRANDE VERS L'AVANT DU MOTO.

Côté droit

- En passant du côté droit de la moto, retirez le boulon du moteur indiqué par une flèche sur la photo 4 à l'aide d'une clé Torx T50.
- En vous référant au schéma d'assemblage du côté droit de la page 3 et illustré sur la photo 3. Faites d'abord glisser une rondelle (article 8) sur le boulon à tête hexagonale le plus long inclus (article 5), suivi de l'une des rondelles dentelées (article 7). Ensuite, faites glisser l'ensemble du boulon à travers l'une des protections crash incluses (article 2), puis faites glisser l'entretoise (article 6) sur l'extrémité exposée du boulon, en vous assurant que l'extrémité conique repose contre la face arrière de la protection crash.
- Fixez la protection crash dans le cadre et le moteur et serrez au couple recommandé.

ATTENTION, LA PROTECTION CRASH DOIT ÊTRE POSITIONNÉE COMME SUR LE SCHÉMA DE LA PAGE 2, AVEC L'EXTRÉMITÉ LA PLUS GRANDE VERS L'AVANT DU MOTO.

Les 2 côtés

- Enfin, installez les capuchons de protection (article 4) sur les deux protections crash, comme indiqué sur la photo 5.
- Avant de rouler, vérifiez que les deux côtés soient bien fixés et que les protections crash ne puissent pas tourner.

R&G

Unit 1, Shelley's Lane, East Worldham, Alton, Hampshire, GU34 3AQ

Tel: +44 (0)1420 89007 Fax: +44 (0)1420 87301 www.rg-racing.com Email: info@rg-racing.com



- Vérifiez régulièrement le serrage de chaque côté.

Découvrez plus de produits R&G pour votre moto sur :
RG-RACING.COM

ISSUE 3 – 13/08/2024 – MH

CONSUMER NOTICE

The catalogue description and any exhibition of samples are only broad indications of the Products and R&G may make design changes which do not diminish their performance or visual appeal and supplying them in such state shall conform to the order. The Buyer acknowledges no representation or warranty (other than as to title) has been given or will apply to the Products other than those in R&G's order or confirmation and the Buyer confirms it has chosen the Products as being of merchantable quality and suitable for its particular purposes. Where R&G fits the Products or undertakes other services it shall exercise reasonable skill and care and rectify any fault free of charge unless the workmanship has been disturbed. The Buyer is responsible for ensuring that the warranty on the motorcycle is not affected by the fitting of the Products. On return of any defective Products R&G shall at its option either supply a replacement or refund the purchase money but shall not be liable if the Products have been modified or used or maintained otherwise than in accordance with R&G's or manufacturer's instructions and good engineering practice or if the defect arises from accident or neglect. Other than identified above and subject to R&G not limiting its liability for causing death and personal injury, it shall not be liable for indirect or consequential loss and otherwise its liability shall be limited to the amounts paid by the Buyer for the Products or the fitting or service concerned. These terms do not affect the Buyer's statutory rights.

R&G RACING RETURNS POLICY (NON-FAULTY GOODS)

Returns must be pre-authorized (if not pre-authorized the return will be rejected). Goods may only be returned direct to us if they were purchased direct from us (customer must prove if necessary). Otherwise to be returned to original vendor. Goods must be in re-sellable condition, in the opinion of R&G Racing. All returns are subject to a 25% restocking and handling fee (25% of the gross value exc. P&P – at the prevailing price at time of purchase). The customer must pay any and all carriage charges. No returns of discontinued products, unless within 14 days of purchase. This policy does not affect your statutory rights and does not refer to fa

R&G

Unit 1, Shelley's Lane, East Worldham, Alton, Hampshire, GU34 3AQ

Tel: +44 (0)1420 89007 Fax: +44 (0)1420 87301 www.rg-racing.com Email: info@rg-racing.com