



**FITTING INSTRUCTIONS FOR BLGFK0050**  
**BRAKE LEVER-GUARD FITTING KIT**



**THIS KIT CONTAINS THE ITEMS PICTURED AND LABELLED OVER PAGE.**

SOME PARTS MAY BE SHOWN FOR CLARITY OF INSTRUCTIONS ONLY.

DO NOT PROCEED UNTIL YOU ARE SURE ALL PARTS ARE PRESENT.

**PLEASE READ ALL INSTRUCTIONS BEFORE PROCEEDING.**

**IF IN ANY DOUBT WHEN FITTING OUR PRODUCTS, CONSULT ONE OF OUR DEALERS  
OR HAVE FITTED BY A QUALIFIED TECHNICIAN.**

PLEASE NOTE THAT THE WAY THE KIT IS PACKED DOES NOT NECESSARILY REPRESENT THE WAY OF  
MOUNTING TO THE BIKE.

IN THE EVENT OF RUBBER WASHERS BEING USED TO HOLD COMPONENTS ONTO BOLTS,  
THESE RUBBER WASHERS CAN BE THROWN AWAY.

**DIGITAL COPIES OF THESE INSTRUCTIONS ARE AVAILABLE FROM:**

[WWW.RG-RACING.COM](http://WWW.RG-RACING.COM)



<b><u>TOOLS REQUIRED</u></b>	<b><u>GENERAL TORQUE SETTINGS</u></b>
<ul style="list-style-type: none"> <li>METRIC ALLEN TOOL SET.</li> <li>SPECIFIC TOOLS REQUIRED TO REMOVE OEM BAR-ENDS, IF APPLICABLE.</li> </ul>	<p>M4 BOLT = 8Nm</p> <p>M5 BOLT = 12Nm</p> <p>M6 BOLT = 15Nm</p> <p>M8 BOLT = 20Nm</p> <p>M10 BOLT = 40Nm</p> <p>M12 BOLT = 40Nm</p>

### **LEGEND**

<b>ITEM NO.</b>	<b>DESCRIPTION</b>	<b>QTY</b>
ITEM 1	PLG0002COMP (LEVER GUARD)	1
ITEM 2	M0685 (THREADED SPACER)	1
ITEM 3	M6 x 1.00 x 50mm CAP HEAD BOLT	1
ITEM 4	M6 x 12mm OD WASHER	1
ITEM 5	NC0008 (M6 NUT CAP) - NOT SHOWN	1

### **EXPLODED ASSEMBLY VIEW**

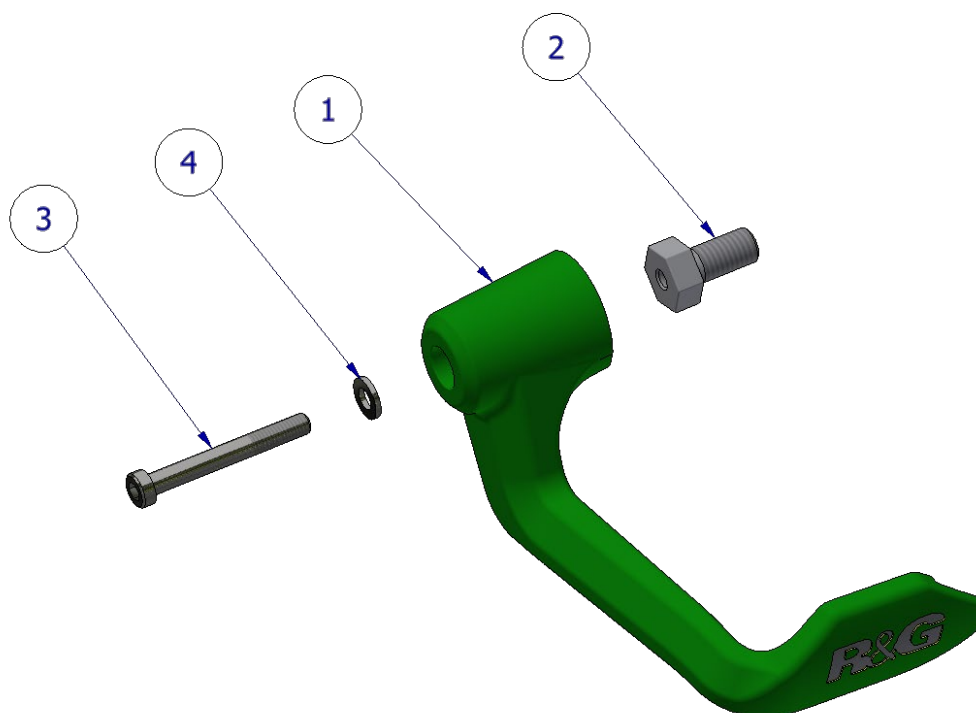

R&G Racing

Unit 1, Shelley's Lane, East Worldham, Alton, Hampshire, GU34 3AQ

Tel: +44 (0)1420 89007 Fax: +44 (0)1420 87301 [www.rg-racing.com](http://www.rg-racing.com) Email: [info@rg-racing.com](mailto:info@rg-racing.com)



## **FITTING INSTRUCTIONS**

- To fit the Brake Lever Guard, you will need to remove the OEM bar ends.
- Thread the M0685 threaded adaptor (**Item 2**) into the bar end & tighten.
- Place the M6 washer (**Item 4**) over the M6 cap-head bolt (**Item 3**), then slide through the brake lever guard (**Item 1**) so the washer sits against the flat surface within the mounting bore.
- Locate the assembly into the thread adaptor and tighten, position so when the motorcycle is at full lock in both directions it does not contact any other part of the motorcycle or **restrict throttle use**.
- Fully tighten the bolt and check operation.
- Finally, push the flat cap (**Item 5**) into the head of the cap-head bolt to give a clean look.

**IMPORTANT - WHEN FITTING THIS PRODUCT, IT IS YOUR RESPONSIBILITY TO ENSURE THAT THE PRODUCT IN NO WAY IMPEDES THE OPERATION OF THE MOTORCYCLE AND IS CHECKED REGULARLY FOR TIGHTNESS AND CORRECT OPERATION.**

**FAILURE TO CHECK THE ABOVE COULD RESULT IN SERIOUS INJURY OR DAMAGE.**

ISSUE 1 - 23/03/2023 (MH)

**See more R&G products for your Motorcycle in the links below:**  
[R&G Racing | Cleaning/Lubrication - Gleam range for All Vehicles \(rg-racing.com\)](#)

### **CONSUMER NOTICE**

The catalogue description and any exhibition of samples are only broad indications of the Products and R&G may make design changes which do not diminish their performance or visual appeal and supplying them in such state shall conform to the order. The Buyer acknowledges no representation or warranty (other than as to title) has been given or will apply to the Products other than those in R&G's order or confirmation and the Buyer confirms it has chosen the Products as being of merchantable quality and suitable for its particular purposes. Where R&G fits the Products or undertakes other services it shall exercise reasonable skill and care and rectify any fault free of charge unless the workmanship has been disturbed. The Buyer is responsible for ensuring that the warranty on the motorcycle is not affected by the fitting of the Products. On return of any defective Products R&G shall at its option either supply a replacement or refund the purchase money but shall not be liable if the Products have been modified or used or maintained otherwise than in accordance with R&G's or manufacturer's instructions and good engineering practice or if the defect arises from accident or neglect. Other than identified above and subject to R&G not limiting its liability for causing death and personal injury, it shall not be liable for indirect or consequential loss and otherwise its liability shall be limited to the amounts paid by the Buyer for the Products or the fitting or service concerned. These terms do not affect the Buyer's statutory rights.

### **R&G RACING RETURNS POLICY (NON-FAULTY GOODS)**

Returns must be pre-authorized (if not pre-authorized the return will be rejected). Goods may only be returned direct to us if they were purchased direct from us (customer must prove if necessary). Otherwise to be returned to original vendor. Goods must be in re-sellable condition, in the opinion of R&G Racing. All returns are subject to a 25% restocking and handling fee (25% of the gross value exc. P&P - at the prevailing price at time of purchase). The customer must pay any and all carriage charges. No returns of discontinued products, unless within 14 days of purchase. This policy does not affect your statutory rights and does not refer to faulty goods.

R&G Racing

Unit 1, Shelley's Lane, East Worldham, Alton, Hampshire, GU34 3AQ

Tel: +44 (0)1420 89007 Fax: +44 (0)1420 87301 [www.rg-racing.com](http://www.rg-racing.com) Email: [info@rg-racing.com](mailto:info@rg-racing.com)



**NOTICE DE MONTAGE POUR BLGFK0050**  
**PROTÈGE LEVIER**



**CE KIT CONTIENT LES ARTICLES ILLUSTRÉS ET ÉTIQUETES SUR LA PAGE.**

CERTAINES PARTIES PEUVENT ÊTRE PRÉSENTES UNIQUEMENT POUR LA CLARTE DES INSTRUCTIONS.

NE PAS PROCÉDER AU MONTAGE TANT QUE VOUS N'ÊTES PAS SÛR QUE TOUTES LES PIÈCES SOIENT PRÉSENTES.

**VEUILLEZ LIRE TOUTES LES INSTRUCTIONS AVANT DE CONTINUER.**

**EN CAS DE DOUTE LORS DU MONTAGE DE NOS PRODUITS, CONSULTEZ UN DE NOS REVENDEURS OU FAITES APPEL À UN TECHNICIEN QUALIFIÉ.**

VEUILLEZ NOTER QUE LA FAÇON DONT LE KIT EST EMBALLÉ NE REPRÉSENTE PAS NECESSAIREMENT LA MANIÈRE DE LE MONTER SUR LA MOTO.

SI DES RONDELLES EN CAOUTCHOUC SONT UTILISÉES POUR MAINTENIR LES COMPOSANTS SUR LES BOULONS, ELLES PEUVENT ÊTRE JETÉES.

**NOTICE DISPONIBLE AU TÉLÉCHARGEMENT SUR :**  
[WWW.RG-RACING.COM](http://WWW.RG-RACING.COM)



<b><u>OUTILS REQUIS</u></b>	<b><u>VALEURS DE SERRAGE</u></b>
<ul style="list-style-type: none"> <li>CLÉ ALLEN.</li> <li>OUTILS SPÉCIFIQUES REQUIS POUR ENLEVER LES EXTRÉMITÉS DE GUIDON D'ORIGINE, SI POSSIBLE.</li> </ul>	M4 BOULON = 8Nm M5 BOULON = 12Nm M6 BOULON = 15Nm M8 BOULON = 20Nm M10 BOULON = 40Nm M12 BOULON = 40Nm

### **LÉGENDE**

<b>ARTICLE NO.</b>	<b>DESCRIPTION</b>	<b>QTÉ</b>
ARTICLE 1	PLG0002COMP (PROTÈGE LEVIER)	1
ARTICLE 2	M0685 (ENTRETOISE FILETÉE)	1
ARTICLE 3	M6 x 1.00 x 50mm BOULON	1
ARTICLE 4	M6 x 12mm RONDELLE	1
ARTICLE 5	NC0008 (M6 CAPUCHON D'ÉCROU) – NON INDIQUÉ	1

### **VUE D'ENSEMBLE**

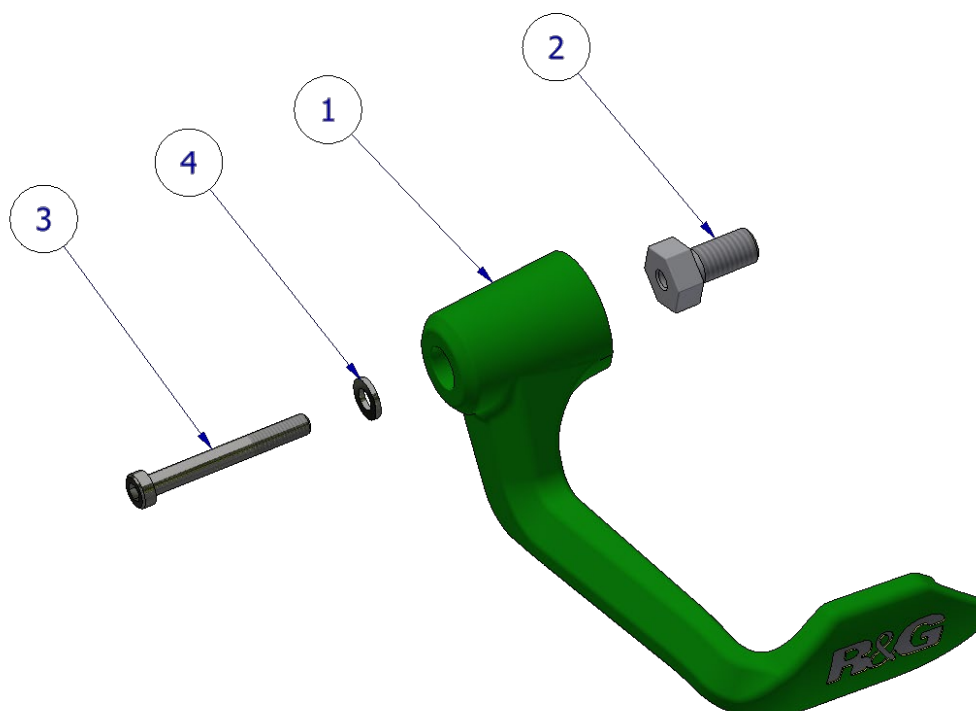

R&G Racing

Unit 1, Shelley's Lane, East Worldham, Alton, Hampshire, GU34 3AQ

Tel: +44 (0)1420 89007 Fax: +44 (0)1420 87301 [www.rg-racing.com](http://www.rg-racing.com) Email: [info@rg-racing.com](mailto:info@rg-racing.com)



## **NOTICE DE MONTAGE**

- Pour installer le protège-levier de frein, vous devrez retirer les embouts de guidon d'origine.
- Vissez l'adaptateur fileté M0685 (article 2) dans l'extrémité du guidon et serrez.
- Placez la rondelle M6 (article 4) sur le boulon à tête cylindrique M6 (article 3), puis faites-la glisser à travers la protection du levier de frein (article 1) de sorte que la rondelle repose contre la surface plane dans l'alésage de montage.
- Placez l'ensemble dans l'adaptateur de filetage et serrez, positionnez-le de sorte que lorsque la moto est complètement verrouillée dans les deux sens, il n'entre en contact avec aucune autre partie de la moto ou ne limite l'utilisation de l'accélérateur.
- Serrez complètement le boulon et vérifiez le fonctionnement.
- Enfin, poussez le capuchon plat (article 5) dans la tête du boulon à tête cylindrique pour un meilleur résultat esthétique.

**IMPORTANT - LORS DE L'INSTALLATION DE CE PRODUIT, IL EST DE VOTRE RESPONSABILITÉ DE VOUS ASSURER QUE LE PRODUIT NE GÊNE EN AUCUN CAS LE FONCTIONNEMENT DE LA MOTO ET SOIT VÉRIFIÉ RÉGULIÈREMENT POUR SON SERRAGE ET SON BON FONCTIONNEMENT.**

**NE PAS VÉRIFIER LES ÉLÉMENTS CI-DESSUS PEUT ENTRAÎNER DES BLESSURES OU DES DOMMAGES GRAVES.**

ISSUE 1 – 23/03/2023 (MH)

**Voir plus de produits R&G pour votre moto via ce lien :**  
[R&G Racing | Cleaning/Lubrication - Gleam range for All Vehicles \(rg-racing.com\)](http://www.rg-racing.com)

### **CONSUMER NOTICE**

The catalogue description and any exhibition of samples are only broad indications of the Products and R&G may make design changes which do not diminish their performance or visual appeal and supplying them in such state shall conform to the order. The Buyer acknowledges no representation or warranty (other than as to title) has been given or will apply to the Products other than those in R&G's order or confirmation and the Buyer confirms it has chosen the Products as being of merchantable quality and suitable for its particular purposes. Where R&G fits the Products or undertakes other services it shall exercise reasonable skill and care and rectify any fault free of charge unless the workmanship has been disturbed. The Buyer is responsible for ensuring that the warranty on the motorcycle is not affected by the fitting of the Products. On return of any defective Products R&G shall at its option either supply a replacement or refund the purchase money but shall not be liable if the Products have been modified or used or maintained otherwise than in accordance with R&G's or manufacturer's instructions and good engineering practice or if the defect arises from accident or neglect. Other than identified above and subject to R&G not limiting its liability for causing death and personal injury, it shall not be liable for indirect or consequential loss and otherwise its liability shall be limited to the amounts paid by the Buyer for the Products or the fitting or service concerned. These terms do not affect the Buyer's statutory rights.

### **R&G RACING RETURNS POLICY (NON-FAULTY GOODS)**

Returns must be pre-authorized (if not pre-authorized the return will be rejected). Goods may only be returned direct to us if they were purchased direct from us (customer must prove if necessary). Otherwise to be returned to original vendor. Goods must be in re-sellable condition, in the opinion of R&G Racing. All returns are subject to a 25% restocking and handling fee (25% of the gross value exc. P&P – at the prevailing price at time of purchase). The customer must pay any and all carriage charges. No returns of discontinued products, unless within 14 days of purchase. This policy does not affect your statutory rights and does not refer to faulty goods.

R&G Racing

Unit 1, Shelley's Lane, East Worldham, Alton, Hampshire, GU34 3AQ

Tel: +44 (0)1420 89007 Fax: +44 (0)1420 87301 [www.rg-racing.com](http://www.rg-racing.com) Email: [info@rg-racing.com](mailto:info@rg-racing.com)