

R&G™



ALUMINIUM TRAIL CRASH BAR-CAB0031BK



Assembly Booklet / Paper collection
Livret de montage / Collecte de papier



Mini Zip Bag / Plastic collection
Mini sac zip / Collecte de plastique



Box / Paper collection
Boîte / Collecte de papier



Carton Separator / Paper collection
Séparateur de cartons / Collecte de papier



Card Header / Paper collection
Carte d'en-tête / Collecte de papier



Plastic Bag Cover / Plastic collection
Couverte de sac en plastique / Collecte de plastique



ASSEMBLY INSTRUCTION / INSTRUÇÃO DE MONTAGEM

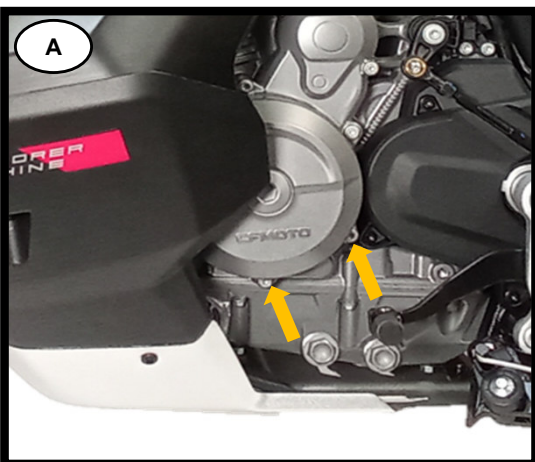

English:

- Remove OEM screws (x2) marked in the photo.

Français:

- Retirer les vis OEM (x2) marquée sur la photo.

Português:

- Remover parafusos OEM (x2) marcado na foto.

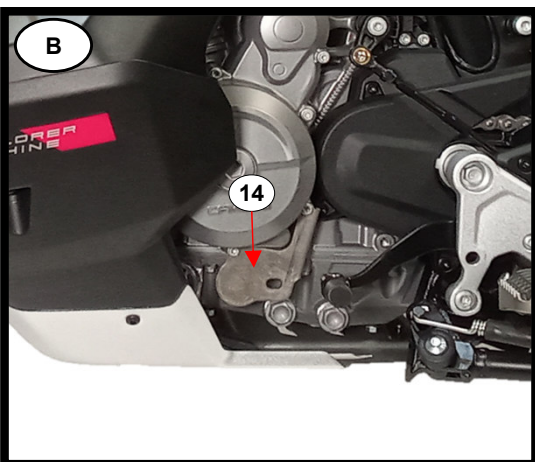

English:

- Mount item N°14 (Stainless Steel Clamp – x1) with OEM screws (x2) according to the photo. Torque all screws to the correct value.

Français:

- Montez l'item N°14 (Fixation Inox – x1) avec les vis OEM (x2) selon la photo. Torque toutes les vis avec le bonne valeur.

Português:

- Montar o item N°14 (Fixação Inox – x1) com parafusos OEM (x2) conforme foto. Apertar todos os parafusos com o valor correto de torque.



English:

- Remove OEM screws (x2) marked in the photo.

Français:

- Retirer les vis OEM (x2) marquée sur la photo.

Português:

- Remover parafusos OEM (x2) marcado na foto.

ALUMINIUM TRAIL CRASH BAR



	N.m	M4	M5	M6	M8	M10	M12
STEEL	8.8	2.7	5.5	9.7	23.0	47.0	80.0
STAINLESS STEEL	A2	2.6	5.1	8.7	21.2	42.0	73.0

17	Carenagem Inferior Direita / Lower Right Crash Bar	R119	1
16	Carenagem Inferior Esquerda / Lower Left Crash Bar	L119	1
15	Fixação Inox / Stainless Steel Clamp	Nº196	1
14	Fixação Inox / Stainless Steel Clamp	Nº153	1
13	Casquilho Alumínio / Aluminium Bushing	Ø20xØ11x25mm	1
12	Casquilho Alumínio / Aluminium Bushing	Ø20xØ9x30mm	1
11	Casquilho Alumínio / Aluminium Bushing	Ø20xØ9x10mm	1
10	Casquilho Alumínio / Aluminium Bushing	Ø20xØ9x5mm	2
9	Porca Freitada FA / Hexagon Flange Lock Nuts	M8 DIN6926 A2	2
8	Anilha / Washer	M8 DIN125 A2	2
7	Parafuso / Screw	M8x45 DIN6921 A2	1
6	Parafuso / Screw	M8x30 DIN6921 A2	1
5	Parafuso / Screw	M8x20 DIN6921 A2	2
4	Parafuso / Screw	M6x25 DIN6921 A2	2
3	Parafuso / Screw	M8x90 DIN912 A2	1
2	Parafuso / Screw	M8x70 DIN912 A2	1
1	Parafuso / Screw	M6x16 DIN912 A2	2
ITEM Nº:	COMPONENTE (COMPONENT):	DESCRIÇÃO (DESCRIPTION):	QUANT.:

ACESSÓRIOS (ACCESSORIES)

ALUMINIUM TRAIL CRASH BAR

R&G



English:

- Torque all screws to the correct value, starting with the union.

Français:

- Torque toutes les vis avec le bonne valeur, en commençant par le raccord.

Português:

- Apertar todos os parafusos com o valor correto de torque, iniciando pela união.

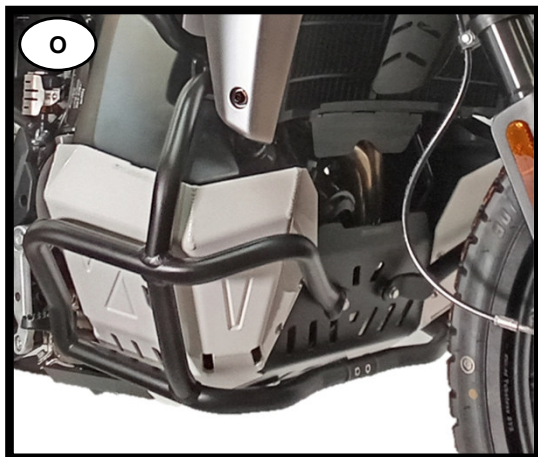

English:

- Engine protection assembly with crash bar of the same brand.

Français:

- Ensemble de protection moteur avec barre de protection de la même marque.

Português:

- Montagem da proteção de motor com carenagem da mesma marca.

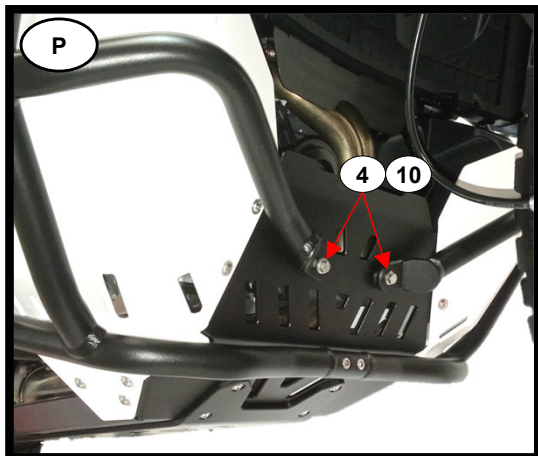

English:

- Engine protection assembly with crash bar of the same brand.

Français:

- Ensemble de protection moteur avec barre de protection de la même marque.

Português:

- Montagem da proteção de motor com carenagem da mesma marca.

ALUMINIUM TRAIL CRASH BAR

R&G



English:

- Remove OEM screw (x1) marked in the photo.

Français:

- Retirer vis OEM (x1) marquée sur la photo.

Português:

- Remover parafuso OEM (x1) marcado na foto.

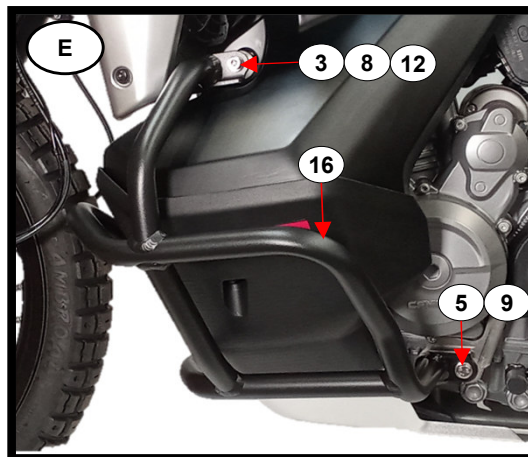

English:

- Apply items according to the photo.

Français:

- Appliquer les items conformément à la photo.

Português:

- Aplicar os itens conforme a foto.

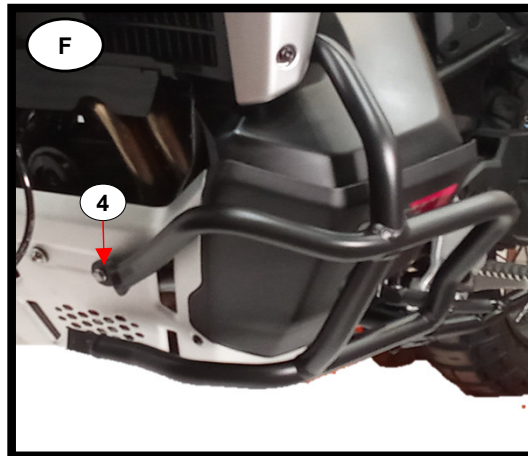

English:

- Appliquer item N°4 (Screw – x1) according to the photo - OEM engine guard assembly.

► **ATTENTION:** If the engine protection is the same brand as the Crash Bar, apply item N°10 (Aluminum Bushing - x1) – see Photo P.

Français:

- Appliquer l'item N°4 (Vis – x1) selon la photo - Ensemble de protection moteur OEM.

► **ATTENTION:** Si la protection moteur est de la même marque que la barre de protection, appliquez l'item N°10 (Bague Aluminium - x1) – voir photo P.

Português:

- Aplicar o item N°4 (Parafuso – x1) conforme foto – montagem com a proteção de motor OEM.

► **ATENÇÃO:** Se a proteção de motor for da mesma marca da Carenagem, aplicar o item N°10 (Casquilho Alumínio - x1) – ver Foto P.

ALUMINIUM TRAIL CRASH BAR

R&G

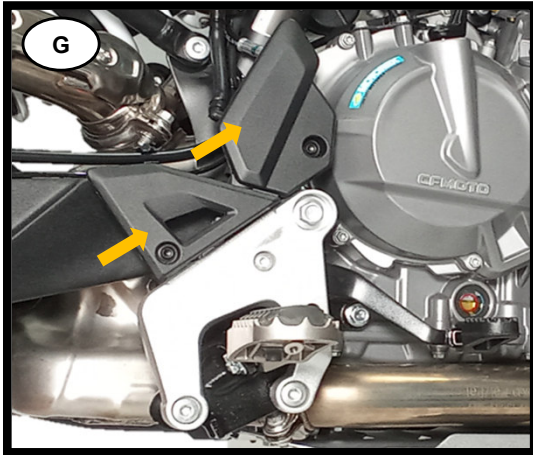

- English:**
 • Remove OEM plastics (x2) marked in the photo.
Français:
 • Retirer plastiques OEM (x2) marqué sur la photo.
Português:
 • Remover plásticos OEM (x2) marcados na foto.

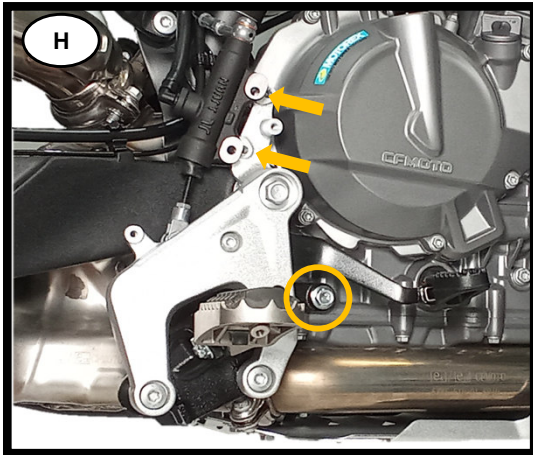

- English:**
 • Remove screws (x2) from the brake pump to remove the marked screw.
Français:
 • Retirez les vis (x2) de la pompe de frein pour retirer la vis marquée.
Português:
 • Retirar parafusos (x2) da bomba de travão para conseguir remover parafuso assinalado.

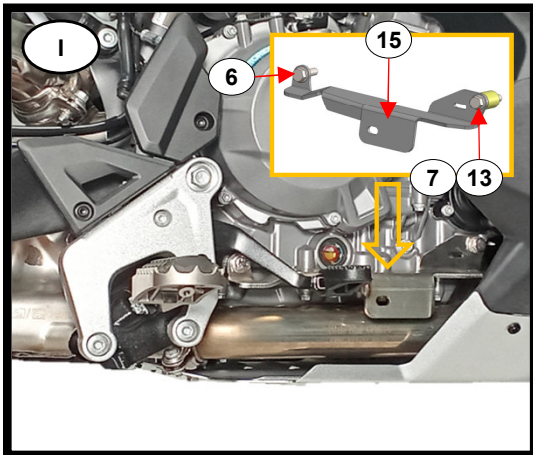

- English:**
 • Apply items according to the photo. Assembling previously removed parts in photos G and H. Torque all screws to the correct value.
Français:
 • Appliquer les items conformément à la photo. Assemblage des pièces précédemment retirées sur les photos G et H. Torque toutes les vis avec le bonne valeur.
Português:
 • Aplicar os itens conforme a foto. Montar peças removidas anteriormente nas fotos G e H. Apertar todos os parafusos com o valor correto de torque.



- English:**
 • Remove OEM screw (x1) marked in the photo.
Français:
 • Retirer vis OEM (x1) marquée sur la photo.
Português:
 • Remover parafuso OEM (x1) marcado na foto.

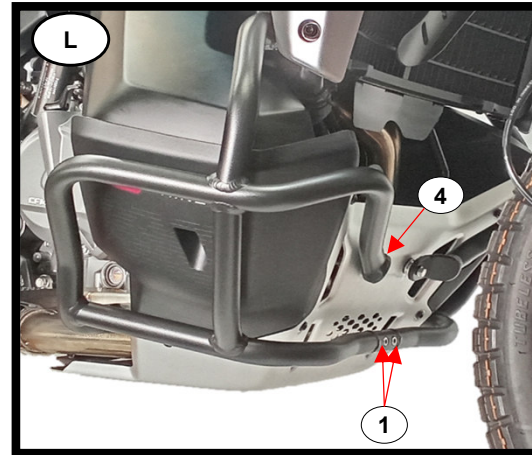

- English:**
 • Appliquer items N°1 (Screw – x2) and N°4 (Screw – x1) according to the photo - OEM engine guard assembly.
ATTENTION: If the engine protection is the same brand as the Crash Bar, apply item N°10 (Aluminum Bushing - x1) – see Photo P.
Français:
 • Appliquer les items N°1 (Screw – x2) et N°4 (Vis – x1) selon la photo - Ensemble de protection moteur OEM.
ATTENTION: Si la protection moteur est de la même marque que la barre de protection, appliquez l'item N°10 (Bague Aluminium - x1) – voir photo P.
Português:
 • Aplicar os itens N°1 (Parafuso – x2) e N°4 (Parafuso – x1) conforme foto – montagem com a proteção de motor OEM.
ATENÇÃO: Se a proteção de motor for da mesma marca da Carengem, aplicar o item N°10 (Casquilho Alumínio - x1) – ver Foto P.

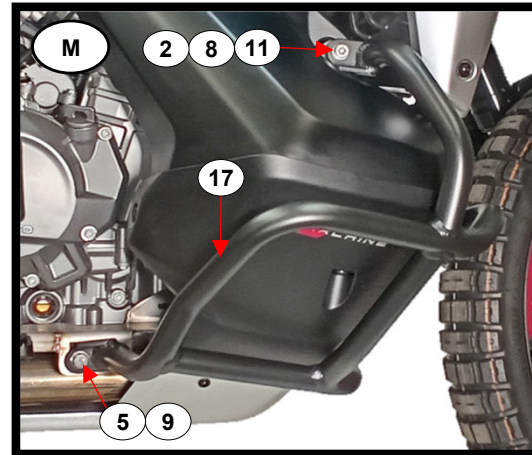

- English:**
 • Apply items according to the photo.
Français:
 • Appliquer les items conformément à la photo.
Português:
 • Aplicar os itens conforme a foto.